



Design Guide

# Optimised Heat and Power

for maximised CHP % share





## Company Profile

Welcome to Origen Energy Limited, we are dedicated to providing the highest quality leading edge technology together with the professional design and after sales service to match our clients specific requirements and needs.

Origen Energy Limited is one of Ireland's leading renewable energy and district heating specialists. We operate from two offices and warehouse facilities in Dublin and one facility in Cork.

We design and supply fully engineered renewable energy and environmental solutions to the residential, commercial and industrial sectors and we can offer in house specialists including design engineers, CAD technicians and system specialists.

The focus of Origen Energy limited is to provide quality solutions that lower energy costs, whilst offering maximum efficiency and comfort. We ensure both domestic and commercial projects are as energy efficient as possible and comply with all necessary energy regulations, guaranteeing a reduced carbon footprint.

Origen Energy limited is part of the Hevac Group which comprises Hevac limited, Tube Company of Ireland Limited and Polytherm Heating Systems Limited.

Origen Energy Limited is recognized as the market leader in the design of environmental and renewable system solutions giving full consideration to reduced carbon emissions and energy savings.

The Origen Energy Team is dedicated to promoting environmental friendly and energy efficient products, through our commitment to the industry and the caring of our employees and the support of our leading brand manufacturing partners from across the world.

## Origen Services

- Expert customer service and technical support
- Comprehensive Products Training
- CPD's available on our Products & Technology
- Full Design and CAD service

## District Heating

We offer full consultancy and technical assistance for design and selection of plant and network.

We can provide a complete system tailoring of your district heating scheme matching your client's specific requirement.

We are the number one supplier for complete district heating system from design, heat generation and transmission pipework to final metering and billing of the energy / heat usage of the end-user.

## Origen Systems

- Air Source Heat Pumps
- Gas Absorption Heat Pumps
- Combined Heat & Power
- Chillers
- Package Plant Rooms
- Photo Voltaic Systems
- Heat Interface Units
- Pre-Paid Billing Systems
- Geothermal Heat Pumps
- District Heating
- Solar Heating
- Cylinders & Buffers
- Biomass Boilers
- Micro CHP
- Energy Metering
- Turnkey Project Solutions

### Contact Details

Muirfield Drive, Naas Road, Dublin 12, Ireland  
Unit L, Furry Park Industrial Estate, Santry, Dublin 9  
South Ring West Business Park, Tramore Road, Cork

Tel: +353 1 419 1940  
Tel: +353 1 842 7037  
Tel: +353 21 432 1066

Fax: +353 1 419 1980  
Fax: +353 1 842 7045  
Fax: +353 21 4321068

E: [energy@origen.ie](mailto:energy@origen.ie)

[www.origen.ie](http://www.origen.ie)

# ■ LoadTracker CHP - DESIGN GUIDE

---

## Contents

1.0. INTRODUCTION .....	4
2.0 ENERGY, COST AND CO <sub>2</sub> EMISSION REDUCTIONS .....	7
3.0 LOADTRACKER CHP OPERATION .....	10
4.0 LOADTRACKER CHP SIZING .....	16
5.0. DESIGN OF BUILDING LTHW FOR INCLUSION OF CHP .....	18
6.0. INSTALLATION .....	25
APPENDICES	
(i) LoadTracker XRGI 6 data sheet.....	28
(ii) LoadTracker XRGI 9 data sheet.....	32
(iii) LoadTracker XRGI 15 data sheet.....	36
(iv) LoadTracker XRGI 20 data sheet.....	40
(v) Heat distributor data sheet .....	44
(vi) Example assessment .....	48
(vii) Example plant room layout .....	52

# ■ LoadTracker CHP - DESIGN GUIDE

---

## 1.0 Introduction

Consulting engineers are facing the challenge of designing buildings which meet building regulations, local planning requirements, deliver low carbon energy and satisfy the occupier's needs. Use of low carbon technologies (such as CHP) calls for a change in design principles. The name of the game is no longer solely to provide comfortable living conditions for occupants but to do so in an energy efficient way that ensures reduced costs and emissions. CHP is recognized as a highly effective technology for reducing CO<sub>2</sub> emissions and energy costs. Specifying CHP can present a range of challenges but LoadTracker CHP has been designed to address many of these challenges, enabling building services engineers to deliver the best solution for their client without compromise.

CHP is the on-site generation of electricity and the simultaneous use of the heat produced as a by-product of the generation process. CHP technology offers significant CO<sub>2</sub> emission reductions and energy cost savings compared to conventional mains electricity and gas-fired boiler heating. This is because electricity and heat generated together on site (CHP) is far more fuel efficient than mains electricity supplied by utility companies.



Figure 1: Installation of two LoadTracker CHP systems.

To achieve the best possible performance from a CHP installation, careful attention must be given to the integration of CHP with the heating circuits. The new CIBSE Guide AM12 identifies the following key objectives for such integration:

1. The CHP unit should operate in preference to the boilers at all times.
2. The CHP unit output remains at maximum when boilers need to be used to meet the demand.
3. The heat recovery from the CHP unit is optimised.
4. The CHP unit should always be able to generate heat, even at part-load.
5. The building heating system should be designed so that return temperatures do not result in the CHP unit shutting down unnecessarily.

LoadTracker CHP with its dynamic outputs, modular set-up, constant flow temperature and active content management storage vessel meets these objectives. For details on CHP integration and design of LTHW systems please see section 5.0 of this guide.

## ■ LoadTracker CHP - DESIGN GUIDE

---

### Key features of LoadTracker CHP

- **Small scale CHP but capable of large loads:** Individual LoadTracker CHP systems are classified as “small scale CHP” because they deliver less than 50 kW of electricity. There are four CHP systems in LoadTracker range, with generating capacity of up to 6, 9, 15 or 20 kW of electricity and 12.2, 19.2, 30.6 or 38.7 kW of heat (outputs relate to a single system of each type). However, units can be combined to serve much higher demands; for example, five XRGI 20 LoadTracker CHP systems have an electrical output of up to 100 kW and heat output of up to 194 kW.
- **Dynamic output:** LoadTracker CHP systems can operate in either heat or power lead mode. In most cases units are operated in power lead mode and are controlled to modulate electrical power generation to match site demand. Each LoadTracker CHP can modulate down to 50% of its full load electrical power output (modulation range depends on type of the CHP, please see Table 2 on page 8 for details). Modulation is virtually instantaneous, ensuring that the electricity generated never exceeds demand. Hence, there is no need to dump heat or sell surplus electricity back to the grid at unfavourable rates.
- **Constant flow temperature:** This is achieved by a heat distributor, able to maintain 80 - 85°C flow regardless of LTHW system return temperatures. This helps to maximize CHP operating hours, minimize boilers running time and hence to maximize cost and carbon savings.
- **Thermal store with active content management:** Surplus heat generated during periods when there is a demand for electricity but little demand for heat is diverted to thermal store vessel. Thermal store enables LoadTracker CHP to run during these periods creating a store of heated water which can then be used later on when a demand for heating arises. Addition of thermal store prolongs CHP operating hours and increases CHP's share in building energy demands.
- **“Plug and play”:** Unlike large scale bespoke CHP systems with fixed outputs that need to be carefully matched to the anticipated building electricity and heating loads LoadTracker CHP can be thought of as “plug and play” units. They can be matched approximately to building loads and will then self-modulate to suit the conditions.
- **Low level of NOx emissions:** LoadTracker CHP systems are characterized with low NOx emissions levels thanks to utilizing lean burn combustion (on XRGI 6 and XRGI 15) or stoichiometric burn with 3 way catalyst (on XRGI 9 and XRGI 20). These highly efficient combustion technologies limit NOx emissions to the TA Luft / half TA Luft standard (German standard for the control of air pollution).

### Operating benefits

- **Low noise emission:** LoadTracker CHP modules achieve a noise level below 50 dB(A) at a distance of 1 meter (about the level to be expected from office conversation).
- **Low maintenance:** LoadTracker CHP utilises an industrial Toyota engine with service intervals of 6,000 - 10,000 hours (depending on the CHP type) and overhaul intervals of approximately 50,000 hours.
- **Independent control:** Each Load Tracker control panel automatically operates and controls the CHP and provides a visual display of its operating condition. No interaction is required with the Building Management System. It is also possible to monitor system operation over the internet using the LoadTracker remote monitoring service.

## ■ LoadTracker CHP - DESIGN GUIDE

---

### Green incentives

- **Reduction of site carbon footprint:** LoadTracker CHP reduces CO<sub>2</sub> emissions as a result of the more efficient use of fuel, relative to power supplies from the grid and heat provided by conventional boilers. The estimated average CO<sub>2</sub> emission from each kWh of electricity supplied by a power station is around 0.5 kg. Gas-fired boilers emit around 0.2 kg of CO<sub>2</sub> per kWh of heat output. Combined on-site generation of electricity and heat is more energy efficient and can result in about 30% reduction in CO<sub>2</sub> emissions.
- **Improved ratings for BREEAM:** CHP can secure significant CO<sub>2</sub> reductions under SBEM (Standard Building Energy Modelling) assessments. This contributes valuable points for assessments carried out under BREEAM, enabling the desired ratings to be secured and smoothing the path to planning approval. Among other Low Carbon Technologies, CHP gives good CO<sub>2</sub> savings relative to the initial capital cost. LoadTracker CHP can improve its contribution further by the low level of NOx emission. LoadTracker's optimised heat and power features can significantly increase the CHP's % share of a building's load.
- **Reduced energy costs:** With LoadTracker CHP, a proportion of site electricity requirements are met using mains gas, thus reducing the overall cost of energy. This is because mains-fed gas is significantly cheaper (currently 2-4 p/kWh) than electricity supplied from the grid (9-13 p/kWh). This means lower energy costs to the end user.
- **Climate Change Levy (CCL) exemption:** The Climate Change Levy, introduced in 2001, is imposed on energy prices for non-domestic buildings. Current (2015) CCL rates are 0.554 p/kWh of electricity and 0.193 p/kWh of gas. Operators of CHP systems can claim CCL exemption on fuel inputs to the CHP system.
- **Enhanced Capital Allowance:** This scheme permits businesses to offset 100% of the capital cost of allowable technologies against corporation or income tax in the first year of the investment, instead of being written down over 4 years. This produces significant improvements to cash flow and reduces the payback period on the initial investment.
- **Energy Efficiency A+++ class:** The new Energy Label applies to CHP systems from September 2015 onwards. The Energy Efficiency label allows consumers to recognise how efficient technical equipment is, enabling them to make economically and ecologically meaningful purchasing decisions. The Energy Labels already well known from white goods market now also include LoadTracker CHP. Owing to its tremendous efficiency, low noise emissions and minimal annual consumption, LoadTracker CHP in a package with Flow Master meets all the criteria to be classified as A+++.

## ■ LoadTracker CHP - DESIGN GUIDE

### 2.0 Energy, cost and CO<sub>2</sub> emission reductions

The Sankey diagram below shows a comparison between a single XRGI 20 LoadTracker CHP system and individual sourcing of electricity from mains supply and heat from conventional boilers. The accompanying table takes account of energy consumption, energy cost and carbon dioxide emission. Assumed energy prices are 3.48 p per kWh for gas and 13.19 p per kWh for grid electricity. Assumed carbon dioxide emissions are 0.216 kg CO<sub>2</sub> per kWh for gas, and 0.519 kg CO<sub>2</sub> per kWh electricity. The assumed efficiency of a gas boiler is 85% (on the basis that few boilers achieve their maximum efficiency due to high return water temperatures).

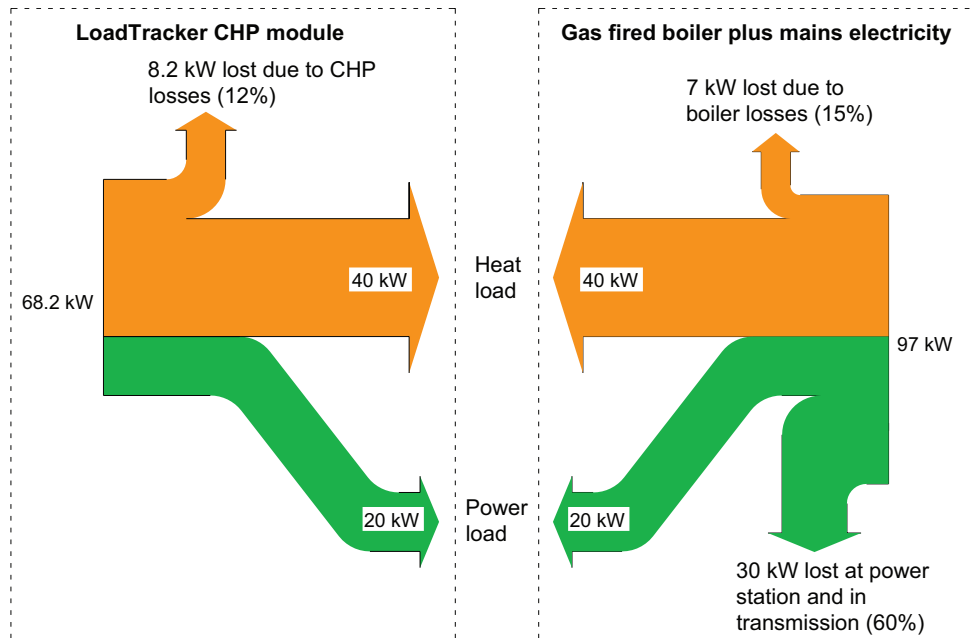

	XRGI 20 LoadTracker CHP	Gas fired boiler plus mains electricity
<b>Input energy (kW)</b>	68.2	97
<b>Energy cost per hour (£)</b>	$68.2 \times 0.0348 = 2.37$	$(47 \times 0.0348) + (20 \times 0.1319) = 4.27$
<b>Emissions per hour (kg CO<sub>2</sub>)</b>	$68.2 \times 0.216 = 14.73$	$(47 \times 0.216) + (20 \times 0.519) = 20.53$
<b>Energy cost saving = 44.5%</b>		
<b>Reduction in carbon emissions = 28.3%</b>		

Table 1: Comparison between LoadTracker CHP and conventional energy supply

## ■ LoadTracker CHP - DESIGN GUIDE

### LoadTracker CHP operating efficiencies

The preceding example assumes that useful heat generated by LoadTracker CHP is approximately twice its electrical output. In reality, the heat to electricity ratio will vary as the unit modulates its electricity output. Table 2 shows the typical variation in performance between minimum and maximum load conditions.

	XRGI 6				XRGI 9			
	Electrical output				Electrical output			
	50% (min)		100% (max)		50% (min)		100% (max)	
Electricity power output [kW]	3		6		4.5		9	
Heat output [kW]	8.2		12.2		12		19.2	
Heat to power ratio	2.7		2.0		2.7		2.1	
	NCV	GCV	NCV	GCV	NCV	GCV	NCV	GCV
Gas input [kW]	11.9	13.1	19.4	21.3	17.3	19.0	29.5	32.5
Electricity production efficiency [%]	25.2	22.9	30.9	28.1	26.0	23.6	30.5	27.7
Heat production efficiency [%]	68.9	62.6	62.9	57.2	69.4	63.1	65.1	59.2
Overall efficiency [%]	94.1	85.6	93.8	85.3	95.4	86.7	95.6	86.9

	XRGI 15				XRGI 20			
	Electrical output				Electrical output			
	50% (min)		100% (max)		50% (min)		100% (max)	
Electricity power output [kW]	7.5		15		10		20	
Heat output [kW]	20.6		30.6		26.1		38.7	
Heat to power ratio	2.7		2.0		2.6		1.9	
	NCV	GCV	NCV	GCV	NCV	GCV	NCV	GCV
Gas input [kW]	30.0	33.0	49.5	54.5	37.1	40.8	61.1	67.2
Electricity production efficiency [%]	25.0	22.7	30.3	27.5	27.0	24.5	32.7	29.8
Heat production efficiency [%]	68.7	62.4	61.8	56.2	70.4	64.0	63.3	57.6
Overall efficiency [%]	93.7	85.2	92.1	83.7	97.3	88.5	96.1	87.3

\*NCV - Net Calorific Value

\*GCV - Gross Calorific Value

The net calorific value of natural gas is determined by taking the gross calorific value and deducting the latent heat of water vapour formed during combustion of hydrogen and from any moisture present in the fuel.

NCV is used by equipment suppliers as a standard reference value for efficiency.

NB: All fuel is purchased on the basis of its gross calorific value, and site energy consumption is also expressed in terms of this. It is therefore important to use GCV in any energy analysis relating to CHP feasibility.

Table 2: LoadTracker CHP efficiency

It can be seen that at full load all units have a better heat to electrical power ratio, for example for XRGI 15 it is 2 to 1. As the unit modulates down to 7.5 kW (equivalent to 50% load), the ratio of heat to power increases to 2.7 to 1. As electricity is typically more valuable than heat, it should be noted that LoadTracker CHP should ideally be operated as close to full load as possible.



# LoadTracker CHP - DESIGN GUIDE

## Energy savings achievable in practice

Conventional fixed-output CHP units are usually sized to match the site base load. As a result, such systems usually achieve only relatively small reductions in the overall energy usage at the site, as they do not contribute to site usage beyond base load. A typical operating pattern for a fixed-output installation is shown in Figure 2.

On the other hand, LoadTracker CHP units are able to modulate their output and hence can achieve far higher energy savings. In multi-unit installations, LoadTracker CHP systems are sequenced automatically to keep in step with swings in demand. This type of operation is illustrated in Figure 3.

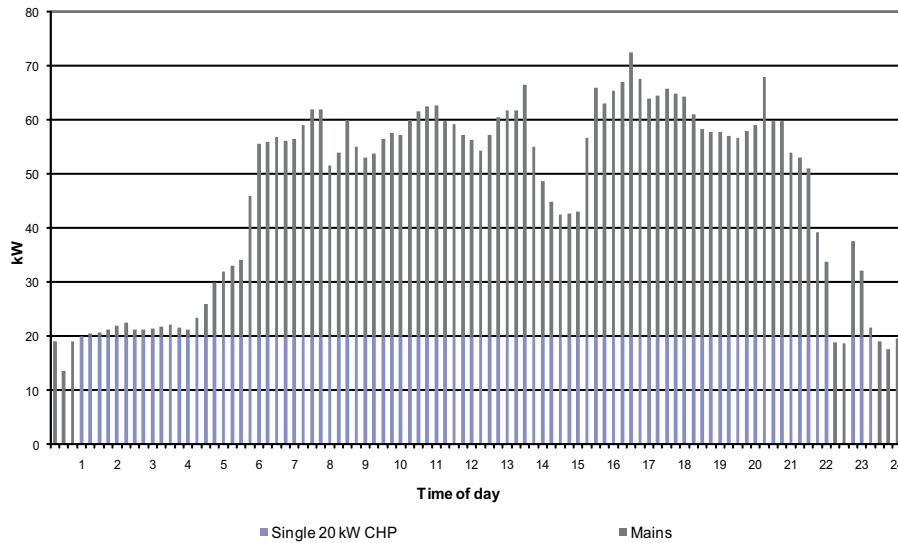

Figure 2: Non-modulating CHP electricity generation - "base load" option

Figure 2 black content shows the actual 24 hour electricity consumption profile of a small leisure centre. Superimposed in blue is the CHP electricity production of a conventional CHP unit, sized to cover base electrical demand only. In this scenario, the CHP would only provide **39% of site electricity usage**. The savings in terms of energy and carbon emissions for this solution are therefore limited.

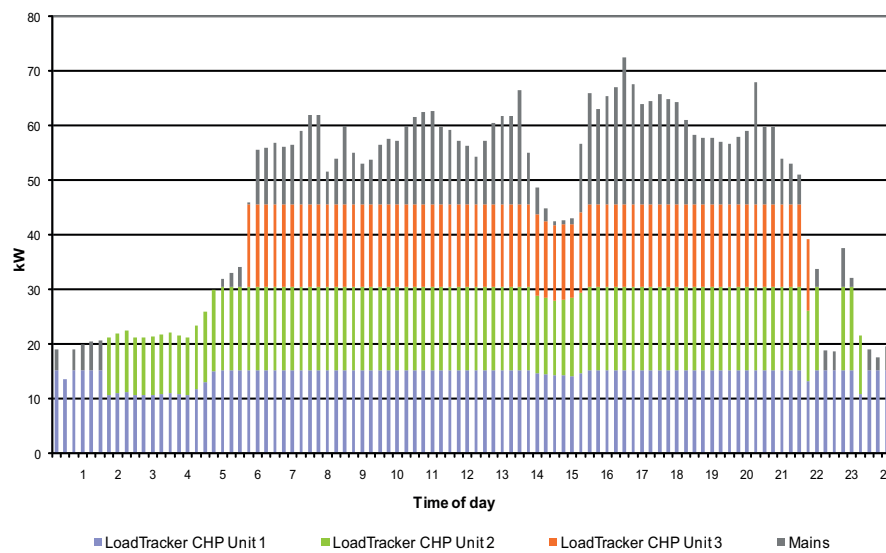

Figure 3: Dynamic LoadTracker CHP - load following operation

Figure 3 shows the electricity production achieved in the same building using a 3-unit LoadTracker CHP solution. By tracking site demand and modulating output accordingly, these CHPs are capable of providing **80% of site electrical demand**.

# LoadTracker CHP - DESIGN GUIDE

## 3.0 LoadTracker CHP operation

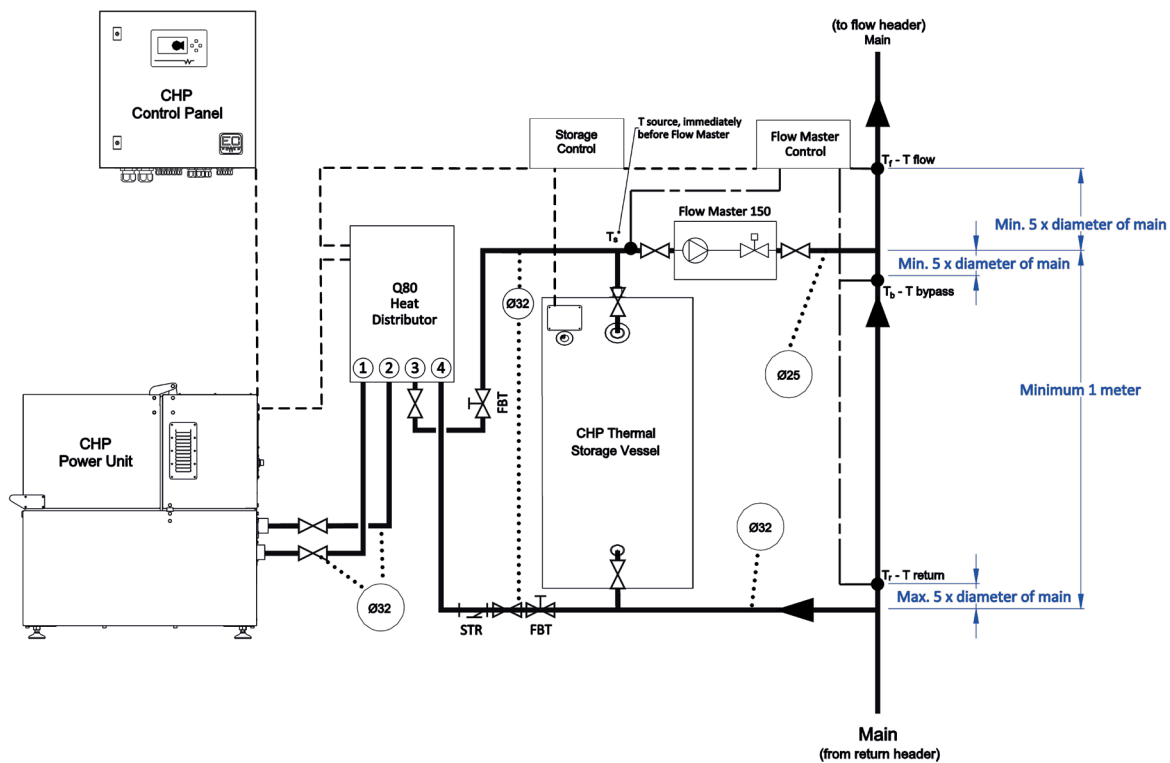

Figure 4: Single LoadTracker CHP installation

Each LoadTracker CHP consists of a power unit, a heat distributor, one or more thermal stores, control sensors and a control panel. The function of each of these is explained in the following paragraphs.

### Power Unit

The power unit comprises a spark-ignition gas engine, generator, heat recovery system and safety control system all within an acoustic enclosure. An industrial model Toyota engine drives an electricity generator. The generator modulates automatically (within its capacity range) to match site electrical demand. The electricity generated is fed into the building's power distribution system. LoadTracker CHP is an asynchronous generator and operates in parallel to the grid.

### Heat Optimiser

The heat distributor creates a hydraulic break between the power unit and the building's heating and DHW system. Figure 6 illustrates Q80 heat distributor.

A closed circuit water cooling system extracts heat from the generator, engine and exhaust gases. This useful heat is then transferred via a plate heat exchanger in the heat distributor and can then be distributed to the site heating and DHW systems. The heat distributor automatically controls both the temperature in the engine cooling system, as well as the flow temperature.

LoadTracker CHP heat distributor generates heat at constant flow temperature of 80°C (rather than operating with constant delta T as many older generation CHPs). In practical terms it means that whenever site heat demands are within CHP capacity, boilers do not have to operate at all. This allows LoadTracker CHP to achieve longer operating hours and higher contribution in site energy demands. As surplus heat is always stored at 80°C, the thermal capacity of the store is optimized.

## ■ LoadTracker CHP - DESIGN GUIDE

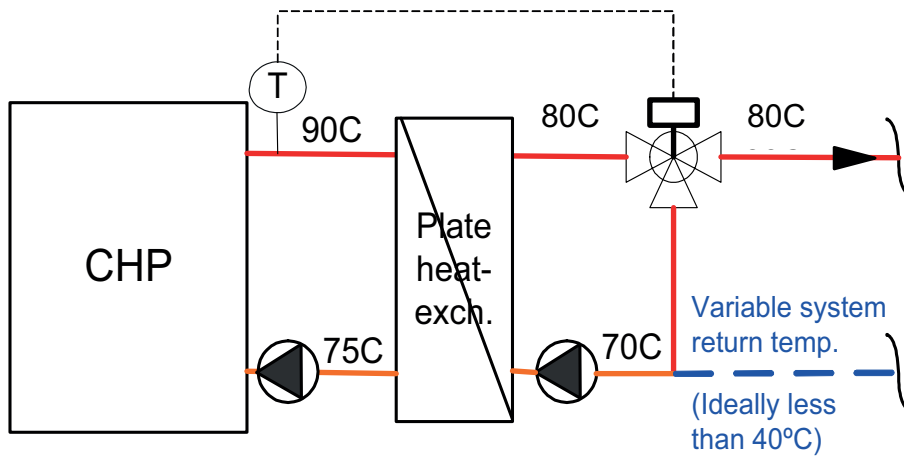
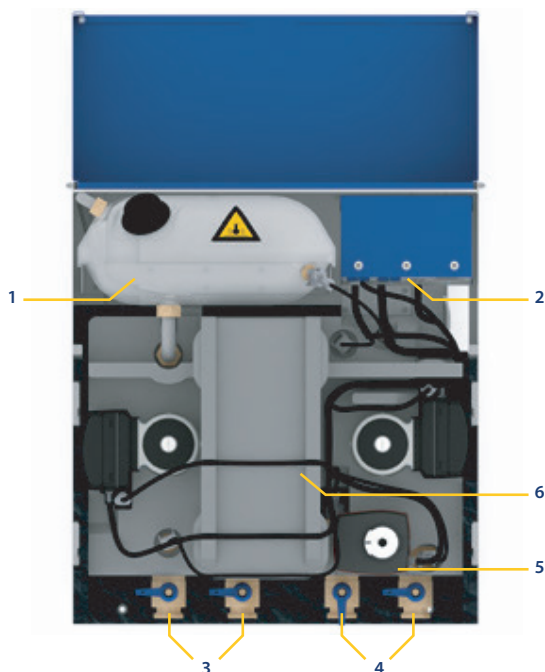

Figure 5: Mixing circuit inside heat distributor



Heat distributors can be provided with either of two sizes of heat exchanger:

- The Q20 heat distributor (for XRGI 6 and XRGI 9) operates with return water temperatures of up to 70°C.
- The Q80 heat distributor (for XRGI 15 and XRGI 20) can operate for limited periods of time with return water temperature of up to 75°C.



Key:

1. Cooling water expansion tank
2. Two connections for Q-Network and two for the iQ-Control Panel and Power Unit.
3. Power Unit connections
4. Storage tank connections
5. Mixer to control the engine temperature
6. Plate heat exchanger

Figure 6: Q80 Heat distributor

The heat distributor consists of a mixing circuit with a motorised valve. The motorised valve will mix a proportion of the flow from the plate heat exchanger with water returning from the heating system. The mixing will be such that a high fixed flow temperature is achieved. Hence, if the water returning from the heating system is at a low temperature, more mixing will occur to bring the temperature up to the set value.

## ■ LoadTracker CHP - DESIGN GUIDE

### Flow Master

The Flow Master regulates the delivery of heat from the LoadTracker CHP system to the main heating system. The Flow Master unit consists of a motorised valve and variable speed pump unit, controlled by the Flow Master Control module. The required flow temperature ( $T_f$ ) can be adjusted on the CHP control panel. This can be set in the range 20 - 80°C, regardless of the site return water temperature. Flow Master adjusts the amount of 80°C water being injected into the main heating system, so the pre-set flow temperature ( $T_f$ ) on the mains is achieved (CHP's 80°C production mixed with site return water).

Variations in heat loads and flow rates are compensated for by the Flow Master valve opening and closing and the pump speed. The flow temperature ( $T_f$ ) is therefore maintained regardless of the heat load. The pump will stop if the Flow Master valve closes completely (i.e. no heat load).

The Flow Master control also automatically prevents reverse flow between the LoadTracker CHP connections on the mains and ensures minimal electricity consumption by the pump.



Figure 7 – Flow Master unit with its control box

## ■ LoadTracker CHP - DESIGN GUIDE

Flow Master can be provided in one of four sizes, as shown in the Table 3 below. The Flow Master selection is based on the LoadTracker CHP thermal output, number of CHP units, thermal store capacity and the heating system delta T. The selection is carried out by Origen.

The nominal heat outputs are based on a delta T of 20°C between the LoadTracker CHP flow and site return, corresponding to a main return of 60 - 65°C. The Flow Master heat outputs will increase proportionally with lower return water temperatures. Flow Master delivers steady regulation down to approximately 2% of max. load.

Flow Master type	Thermal output	$\Delta T$ (at return of 60 to 65°C)	Maximum flow rate
<b>FM 50</b>	50 kW	20°C	2.2 m <sup>3</sup> /h
<b>FM 150</b>	150 kW	20°C	6.5 m <sup>3</sup> /h
<b>FM 250</b>	250 kW	20°C	10.8 m <sup>3</sup> /h
<b>FM 350</b>	350 kW	20°C	15.1 m <sup>3</sup> /h

Table 3: Flow Master range

The motorised valve within Flow Master will open to allow flow to the heating system when there is a demand. Where there is no demand, the valve closes resulting in zero flow to the heating system.

With continuing electricity needs but a reduced demand for heating system, the motorized valve closes and hot water will be forced into the thermal store. Conversely, when there is demand for heating, hot water will be forced out of thermal store and pumped into the heating system.

If the heat load is greater than the heat produced by CHP, the thermal store will discharge. When the thermal store has fully discharged, the supply temperature  $T_s$  for the Flow Master will fall and the Flow Master Control accordingly calculates a maximum supply temperature  $T_f$  as basis for control.

The Flow Master Control automatically adjusts to actual flow rates and return temperature conditions to achieve stable and precise control.

Flow Master operation is based on readings from four temperature sensors connected to the Flow Master Control box: T return, T bypass, T source and T flow. Flow Master temperature sensors should be installed in the screw-in pockets (35 mm fitting length, male thread 1/2" pipe) provided within CHP installation kit. Sensors locations are indicated on mechanical schematics, as for example shown in Figure 4 on page 10.

## ■ LoadTracker CHP - DESIGN GUIDE

---

### Thermal Store

The thermal vessel stores heated water until it is needed by the heating system. LoadTracker thermal stores are equipped with internal diffusers to maintain stratification between the higher temperature flow water supplied by the heat distributor and the lower temperature heating system return water. This means that the thermal storage capacity of the vessel is maximised.

### Other benefits to LoadTracker thermal store are as follows:

- It enables the CHP unit to achieve reasonable operating cycles during periods of low site heat demand. This reduces the frequency of engine restarts.
- It enables heat demand greater than the power unit maximum output to be met for temporary periods. This increases CHP operating time and reduces the need for back-up gas boilers.
- Conversely, it allows heat demands smaller than the minimum output of the CHP power unit to be met for limited periods. Again, this results in operation by the CHP being increased and the gas boiler activity being curtailed.
- It enables more frequent operation at full load (rather than part load) by the CHP unit. This means that operating efficiency is increased.
- It allows the optimising of LoadTracker CHP operating time e.g. the system can operate during high tariff electricity periods even without site heat demand, by diverting heat to the storage vessel.

Thermal storage allows LoadTracker CHP to achieve higher share in peak demands, higher than it would be possible with delivering direct heat output only. Surplus heat stored in a vessel during base load period is discharged to the heating system during peak load. Thermal storage capacity increases in relation to the temperature differential. As LoadTracker CHP delivers constant flow temperature of 80°C, low heating system return is important for maximizing storage capacity. Variable flow systems with a 30 - 40°C design temperature differential are therefore ideal.

For example 1000 litres heat storage with delta T of 20°C (80/60) has capacity of 23 kW. The same 1000 litres storage with delta T of 40°C (80/40) has capacity of 46 kW. Therefore by increasing delta T the same size of storage has double heat content. On an example presented in Figures 8 and 9 opposite, CHP with 23 kW storage capacity can provide 70% share in heat demands. While CHP with 46 kW storage can deliver 77% share in site heat demands.

## ■ LoadTracker CHP - DESIGN GUIDE

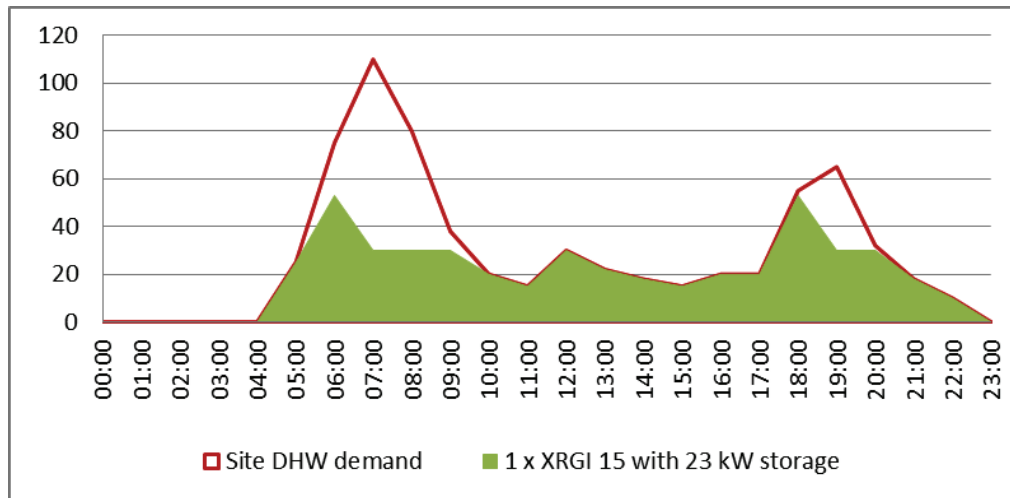

Figure 8: LoadTracker share in heat loads; XRGI 15 with 23 kW storage

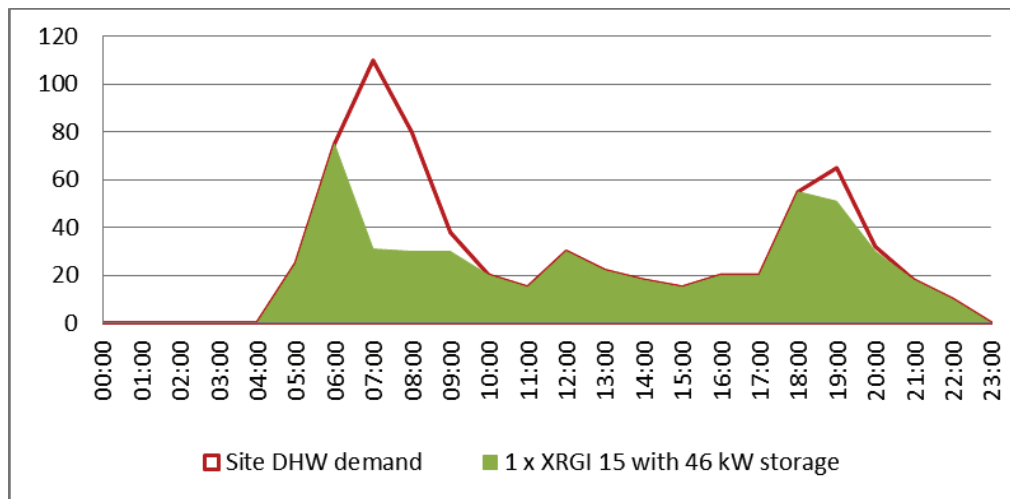

Figure 9: LoadTracker share in heat loads; XRGI 15 with 46 kW storage

The proportion of hot and cold water in the thermal store varies according to operating conditions. When the power unit produces *more* heat than the building requires, heated water is pushed into the store. Alternatively when the power unit produces less heat than that required at site, heated water is evacuated from the store to help meet demand. A horizontal separation layer is maintained inside the storage vessel, between the hot flow water (80°C) from the heat distributor and the cooler water returning from the building heating system. This separation layer is an essential part of LoadTracker's system control.

As the layer moves up and down in the storage vessel, its position is monitored by thermal probes located along the side of the vessel. This information is fed back to the LoadTracker CHP control panel and is used for instructions to start up / shutdown.

When the store contains only hot water and there is no site heating demand, the power unit would be in stand by mode. This remains the case even with continuing electricity demand. When heating demand is re-established, heated water from the upper part of the thermal store is pumped initially to the site heating circuits. As the store empties, the separation layer moves upwards and a CHP start signal is generated from the thermal probes.

## ■ LoadTracker CHP - DESIGN GUIDE

The LoadTracker CHP controller “learns” the site load patterns and optimises the controls to anticipate expected changes in demand. The control system obtains its signals from the probe best suited to the site pattern. Each storage vessel is provided with a minimum of 4 thermal probes, with larger storage vessels being provided with either 8 or 12 probes to provide accuracy of control. All sensors are connected to the LoadTracker CHP control panel via a hard wired Q-network.

Start / stop signals from the thermal probes can also be used to control heat pumps and back-up conventional gas boilers. However, the controller always gives priority to CHP operation.

In order to maximise CHP running times, the thermal storage vessel must be configured to encourage stratification of hotter flow and cooler return layers. Hence, tall cylinders are preferred with only two connecting pipes located from the sides and with built-in diffusers. This helps to minimise turbulence and unwanted mixing of water inside the storage vessel. The recommended arrangement for vessel mounting is shown in Figure 10 below.

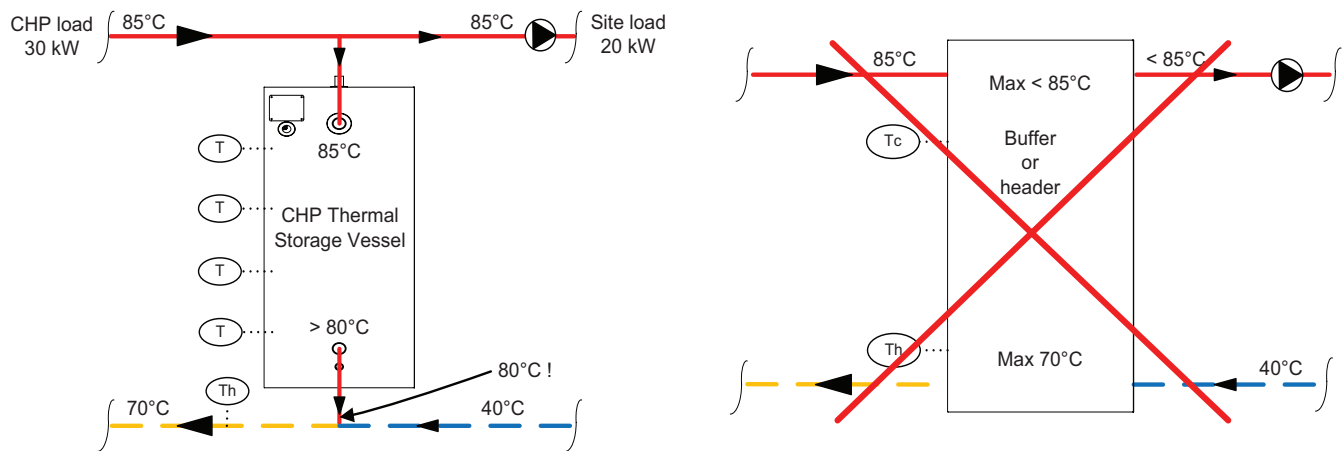

Figure 10: The storage vessel connections

The minimum required LoadTracker storage capacity for sites with low peak loads is 500 litres per CHP unit. Buildings with high peak loads in heating and DHW demand should have 1,000 litres per unit. For larger sites with 2 or more CHP units, multiple thermal storage vessels are connected in series.

### Control Panel

Each power unit comes with its own control panel, which allows LoadTracker CHP to adjust its production automatically to site electrical and heat demands. The system follows the fluctuations in site demand over daily and seasonal cycles. This dynamic response is instrumental to maximizing LoadTracker CHP running hours.

The control panel incorporates mains monitoring and protection relay, as required by G83 or G59 Engineering Recommendations (respectively to the size of CHP system used).

Performance data for each LoadTracker CHP unit can be viewed on the control panel display. In addition, remote monitoring via the website is also possible using a control panel SIM card. Access to this information is offered through the LoadTracker remote monitoring service.

## 4.0 LoadTracker CHP Sizing

Due to the modular design approach, sizing the correct number of LoadTracker CHP units is relatively straightforward. There is no necessity to provide detailed records of electricity and heating energy consumption as required when sizing large scale, base load CHP solutions.



## ■ LoadTracker CHP - DESIGN GUIDE

To assess the energy saving potential of LoadTracker CHP for an existing site all that is required is a record of gas and electricity consumption. This can usually be obtained from utility bills or meter readings. Monthly readings give information which is sufficiently accurate to allow an annual profile to be constructed. However, if the information available is less comprehensive than this, an annual profile can be simulated based on the building type and location.

For new builds, a theoretical estimate of expected thermal and electrical loads in kWh will be required to enable assessment of CHP to be carried out. Seasonal factors should be taken into account: whereas domestic hot water usage could be expected to remain steady throughout the year, space heating would be high in winter but would be discontinued during the summer months.

LoadTracker CHP systems can be installed in a wide variety of buildings, but they are not suitable for every project. Site suitability should be assessed on a project by project basis. A feasibility study should examine the anticipated reduction in carbon footprint and projected cost savings. Given that suitability can be demonstrated at any particular site, then total LoadTracker CHP capacity and thermal storage volume can then be selected in such a way as to maximise CHP running times.

Figure 11 shows a typical comparison between actual building loads and those predicted by simulation software.

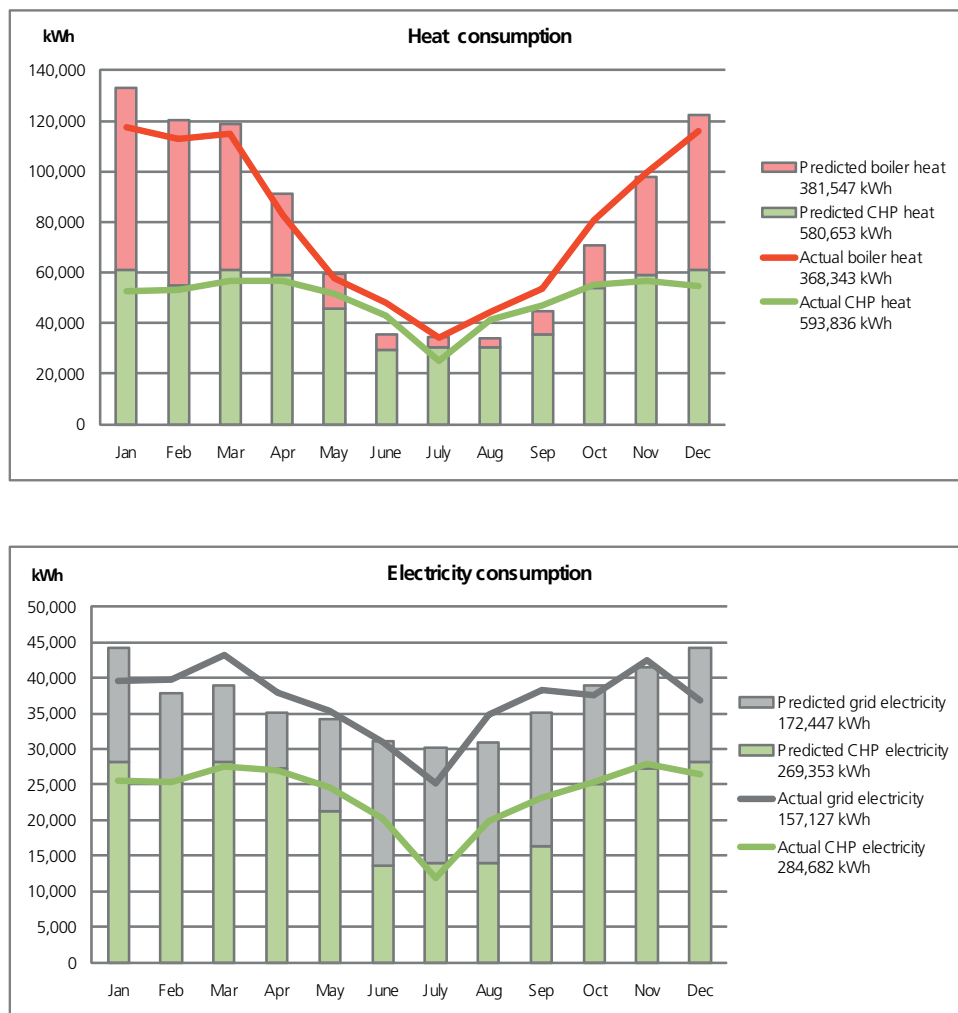

Figure 11: Comparison between actual and predicted building load profiles

## ■ LoadTracker CHP - DESIGN GUIDE

---

### 5.0 Design of building heating systems for inclusion of CHP

To achieve the best possible performance from a CHP installation, careful attention must be given to the integration of CHP with the heating circuits. The new CIBSE Guide AM12 identifies the following key objectives for such integration:

1. The CHP unit should operate in preference to the boilers at all times.
2. The CHP unit output remains at maximum when boilers need to be used to meet the demand.
3. The heat recovery from the CHP unit is optimised.
4. The CHP unit should always be able to generate heat, even at part-load.
5. The building heating system should be designed so that return temperatures do not result in the CHP unit shutting down unnecessarily.

LoadTracker CHP can be incorporated into a heating system either in series or in parallel with boilers. In both cases, the main design principles are as follows:

A. The heating system design temperature differential (delta T i.e. flow temperature minus return) should be at least 30°C. This maximises heat recovery from the CHP unit, thermal storage capacity (thereby reducing the size of the store) and the whole system efficiency. This temperature differential is important in maintaining a trackable separation layer inside the thermal store, thereby enabling optimum control of the whole LoadTracker CHP system (as explained in section 3, thermal store).

Furthermore, the design of secondary circuits should ensure that the return water temperature cannot increase under part load conditions. Secondary circuits with constant flow and 3- or 4-port diverting control valves should be avoided, as diverted flow effectively bypasses the heat emitter and increases the return temperature.

Secondary circuits should be designed for variable flow. This approach calls for 2-port temperature control valves placed locally to heat emitters, resulting in lower flows at part loads with attendant savings in pump energy. This solution ensures that the return temperature cannot increase above its full load design value.

It should be noted that the ability of variable flow systems to provide reduced return temperatures may be negated, if excessive water is allowed to circulate through fixed or controlled by-passes. By-passes are often incorporated into variable flow systems, in order to maintain at least a minimum level of flow through the pump. A further reason is to ensure that water treatment chemicals are kept circulating round system extremities under part load conditions. The amount of water that is permitted to by-pass back to the return pipe should be minimised. As a rule of thumb, the amount of this bypass water should not exceed 5% of the full load design flow rate under all operating conditions.

In order to realise the predicted energy saving benefits of commercial heating systems and heating networks, it is essential that pipework distribution systems are designed with proper regard to system operating temperatures.

“Delta T” is an acronym for the difference in temperature between the flow and return water in a piped heating distribution system. The selection and maintenance of system flow and return temperatures should be the over-riding design consideration that has to take priority over all others if the energy and cost saving potential of the system are to be realised.

In cases where the anticipated energy savings of heating distribution systems fed from low carbon heat sources (such as CHP) fail to materialise, it is almost always choice of delta T, or the inability to maintain the delta T that is wrong.

There are key objectives of successful delta T designs:

- The operating delta T across heat source should be as close as possible to their optimal design values. This will enable them to operate at close to the peak efficiencies.
- The delta T across secondary distribution circuits should be maximised. This will give rise to lower system flow rates, smaller pipes and smaller pumps that consume less energy. Furthermore, buffer vessels or thermal stores can be reduced in size relative to the size of the system.

## ■ LoadTracker CHP - DESIGN GUIDE

---

- Secondary flow and return water temperatures must be maintained at as low values as possible. This will help to minimise pipe distribution heat losses.
- B. Constant temperature circuits deliver water to heat emitters at a constant temperature under all operating conditions. These systems are best suited to fan coil and air handling units. They are ideally suited to variable flow control. Under part load conditions, both the flow rate and return temperature reduce from their design values. Advice on system design is provided in CIBSE KS7, Variable Flow Pipework Systems.
- C. Variable temperature (mixing) circuits enable the flow temperature to a heating circuit to be varied. This type of circuit is commonly used to serve radiator systems, where the flow temperature is varied conversely with outside air temperature. Such controls are known as 'weather compensated'. Variable temperature circuits are usually based on variable flow. For example, thermostatic valves on radiators act to throttle flow in order to meet desired temperatures, and reduced flows lead to reduced return temperatures under part load conditions.
- D. DHW calorifiers are not compatible with systems that require large temperature differentials between flow and return and are consequently not well suited to LoadTracker CHP applications. To maintain stored water at 60°C, the return water temperature would have to be higher than this, making it impossible to maintain a temperature differential of at least 30°C below flow temperature. To avoid this difficulty, domestic hot water can instead be provided instantaneously by means of heat interface units incorporating accurate temperature and pressure control valves. Heat interface units incorporate plate heat exchangers to heat hot water instantaneously resulting in heating water return temperatures in the range 15-30°C. This enables compliance with the latest industry guidance for heating networks.

For example, CIBSE's AM12 (2013) "Combined heat and power for buildings" section 9.16, Design of district heating states:

*"It is recommended that, for new systems, radiator circuit temperatures of 70°C (flow) and 40°C (return) are used with a maximum return temperature of 25°C from instantaneous domestic hot water heat exchangers."*

CIBSE "Heat networks: Code of Practice for the UK" states that: *"Best practice could include the use of heating systems with return temperatures below 40°C."*

*"Best practice would aim to achieve return temperatures below 55°C for a scheme supplying only existing buildings and below 40°C for a scheme supplying only new buildings."*

Accurate control of the heat transfer across the plate heat exchanger is the key to achieving uninterrupted hot water supplies and consistently low heating return temperatures.

A unique feature of Danfoss FlatStations is the inclusion of patented Danfoss thermostatic and pressure control valves. These specially designed valves provide the following significant performance benefits relative to alternative products:

- faster response time
- more accurate control of hot water flow temperature
- reduced heat losses during idle periods
- reduced primary flow rates
- reduced primary return temperatures
- optimal hydraulic balancing of the primary central heating network

## ■ LoadTracker CHP - DESIGN GUIDE

### Series connection

Figure 12 shows a schematic diagram of a typical heating system incorporating LoadTracker CHP installed in series with boilers. This solution meets all the CIBSE Guide requirements. For the purposes of the description below, primary circuits are defined as those on the heat generator side of the flow & return headers. The site heating circuits are referred to as secondary circuits.

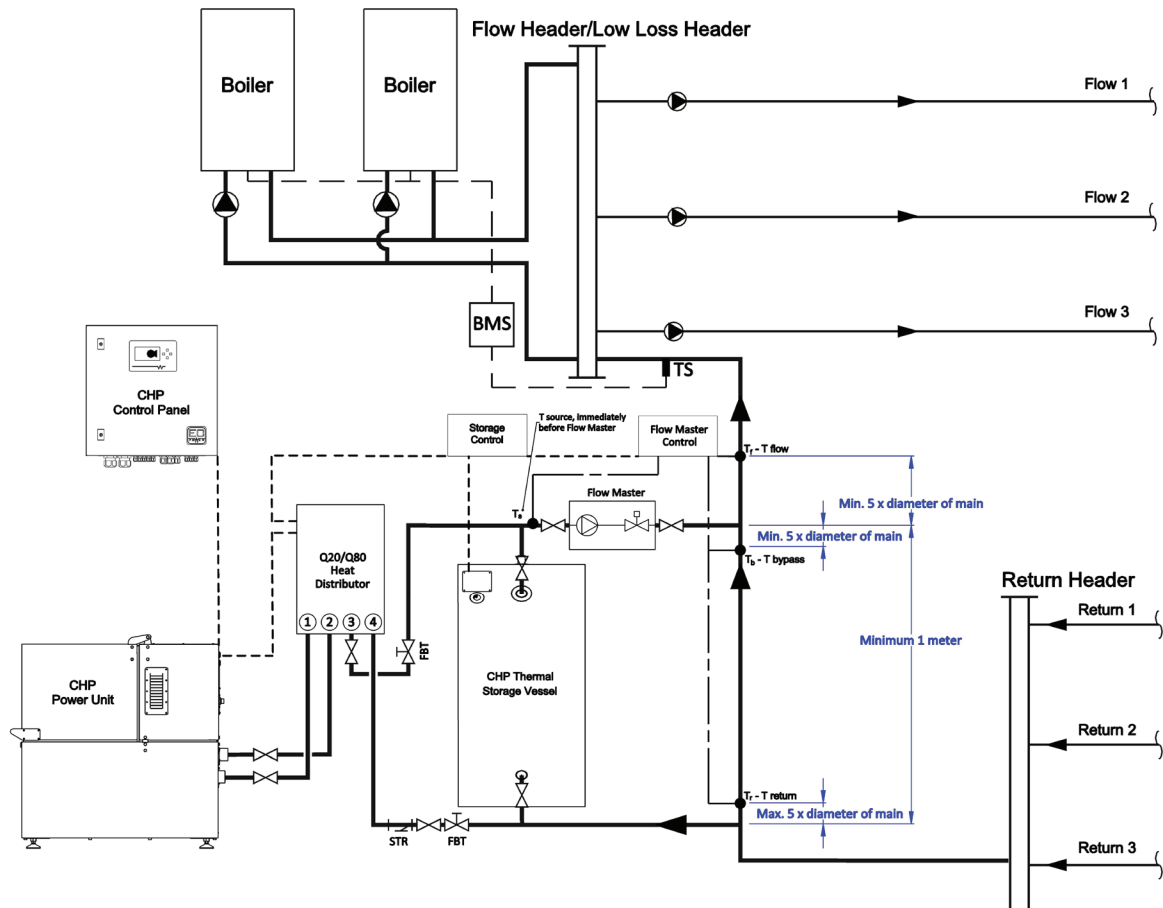

Figure 12: Heating system with a single LoadTracker CHP connected in series with boilers

Separate headers should be provided for secondary connections. The LoadTracker CHP unit should then be connected between the return and flow headers as shown in Figure 12. By separating the secondary flow and return connections in this way, the risk is removed of hot boiler primary flow water mixing with cooler return water before reaching the LoadTracker CHP unit. The LoadTracker CHP pumps (built into the heat distributor) pull water out of the return pipe at low temperature and push heated water back into the same pipe before it reaches the boilers.

If the LoadTracker CHP system can satisfy site thermal demand, it will deliver flow water at the desired temperature to the secondary circuits and boilers will not be required. This helps to minimise boiler running time and hence to maximise cost and carbon savings. Hence the running time of the boilers is minimised. However, if site demand cannot be met by LoadTracker CHP, the desired secondary flow temperature will not be achieved and the back-up boilers should be started up. Boilers should be controlled by a temperature sensor located on the return line, downstream of the LoadTracker CHP flow connection.

Flow temperature is governed by Flow Master.

## ■ LoadTracker CHP - DESIGN GUIDE

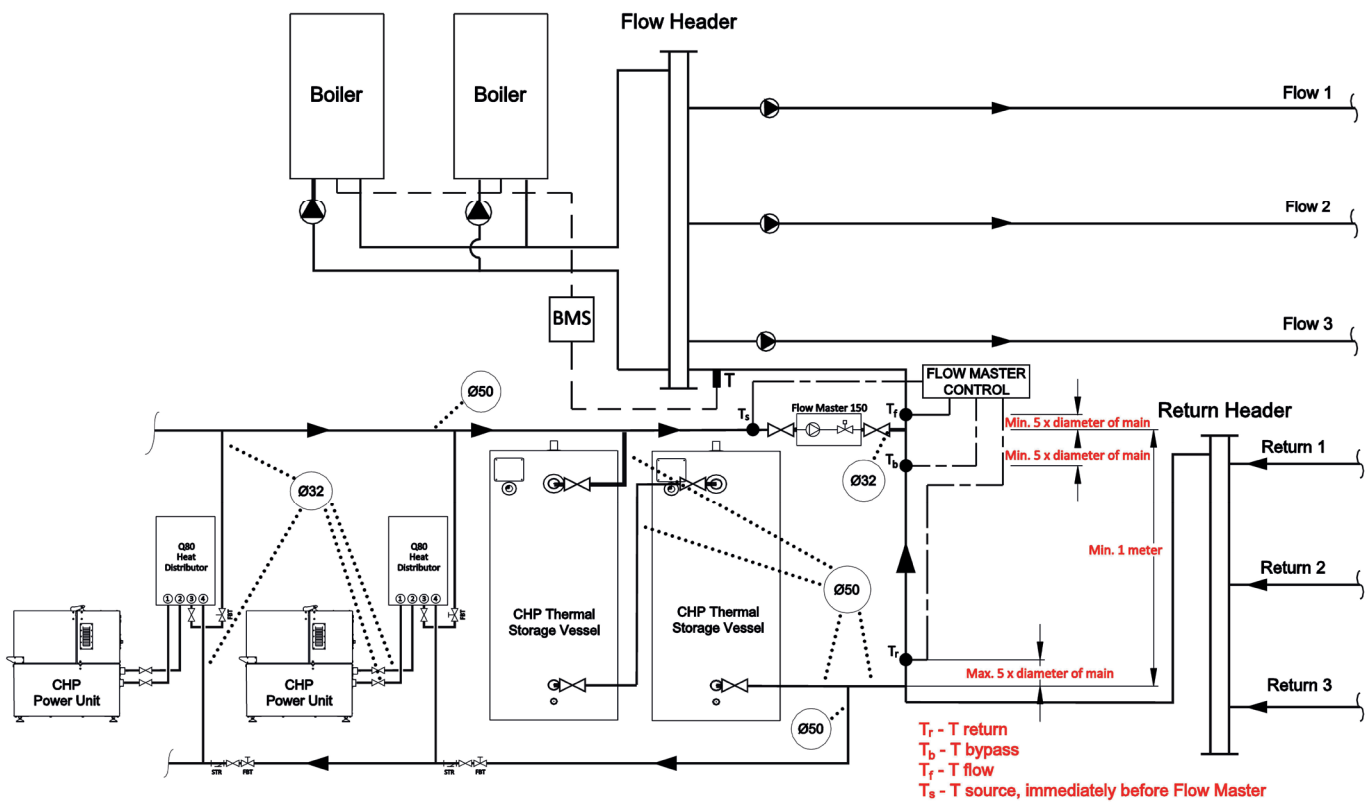

Figure 13: Heating system with multiple LoadTracker CHP units connected in series with boilers

Installations with multiple LoadTracker CHP units also can be placed in series with boilers (it is only the CHP units that are placed in parallel with each other). Design principles remain similar to those used for single CHP installations. With multiple LoadTracker CHPs, a larger Flow Master unit will be used.

### Parallel connection

Figure 14 shows a schematic diagram of a heating system incorporating LoadTracker CHP installed in parallel with the boiler. This layout is recommended where heating system return temperatures are low (preferably below 40°C) and LoadTracker CHP can provide the majority of site heat and DHW demand.

# LoadTracker CHP - DESIGN GUIDE

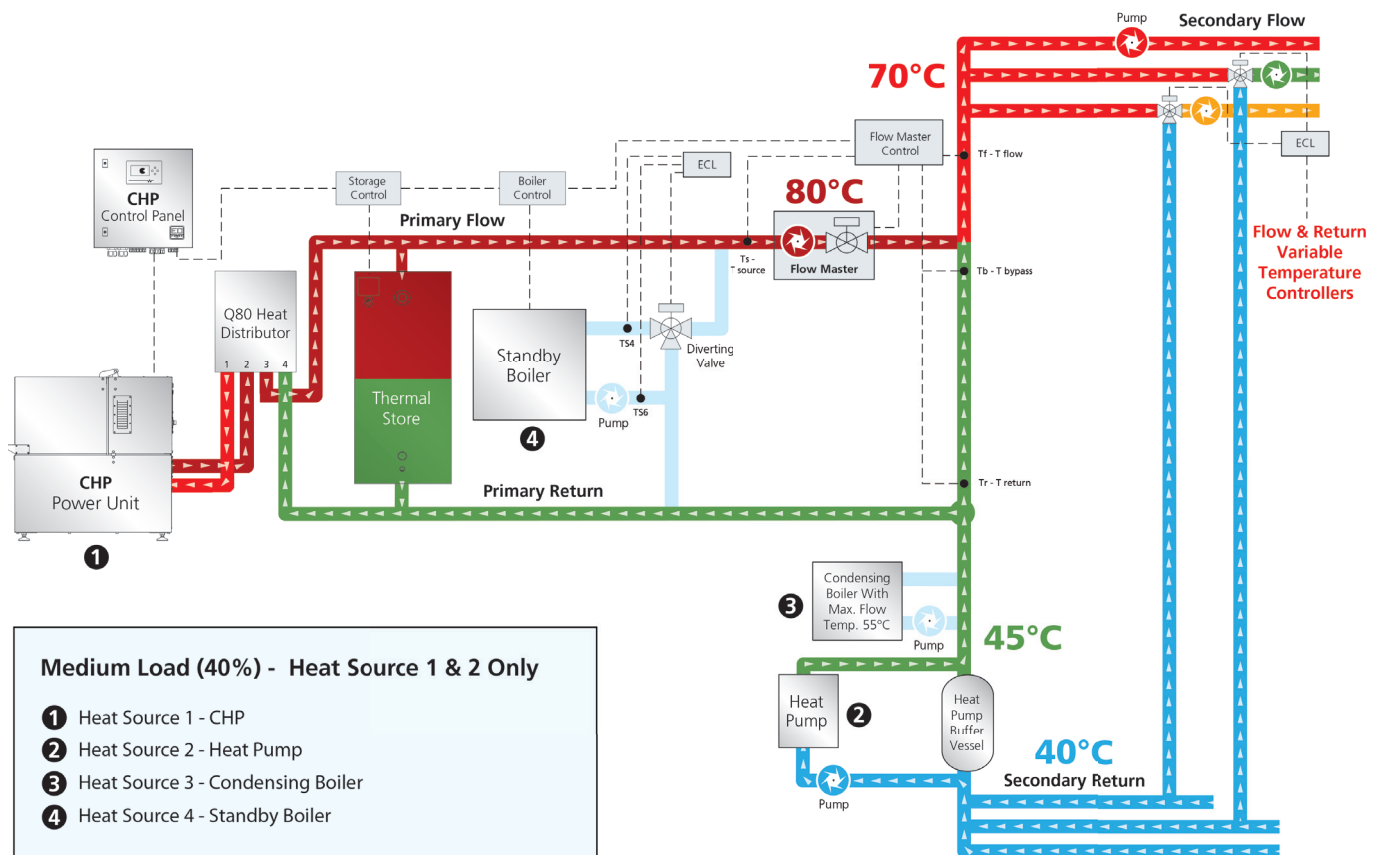
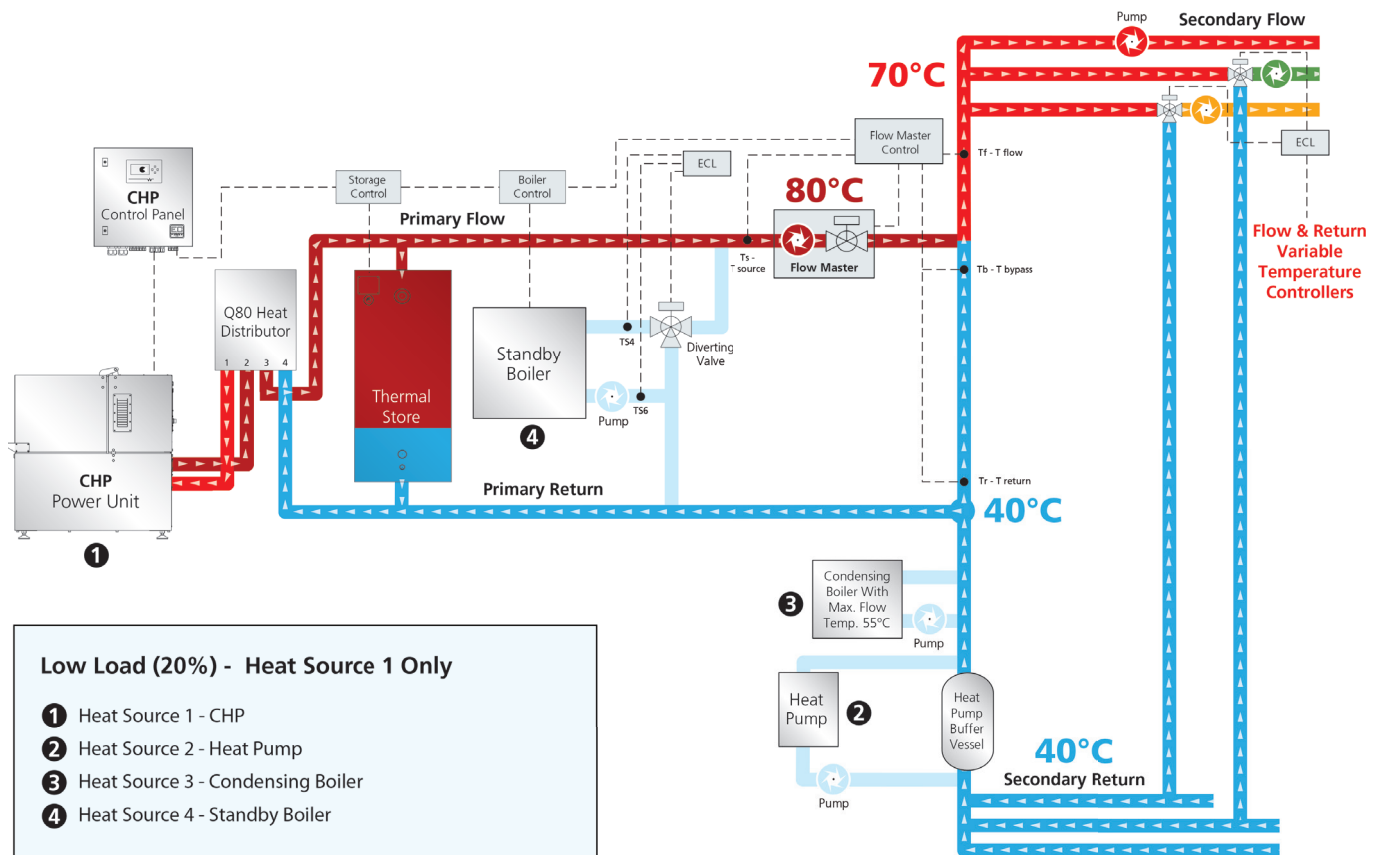

# LoadTracker CHP - DESIGN GUIDE

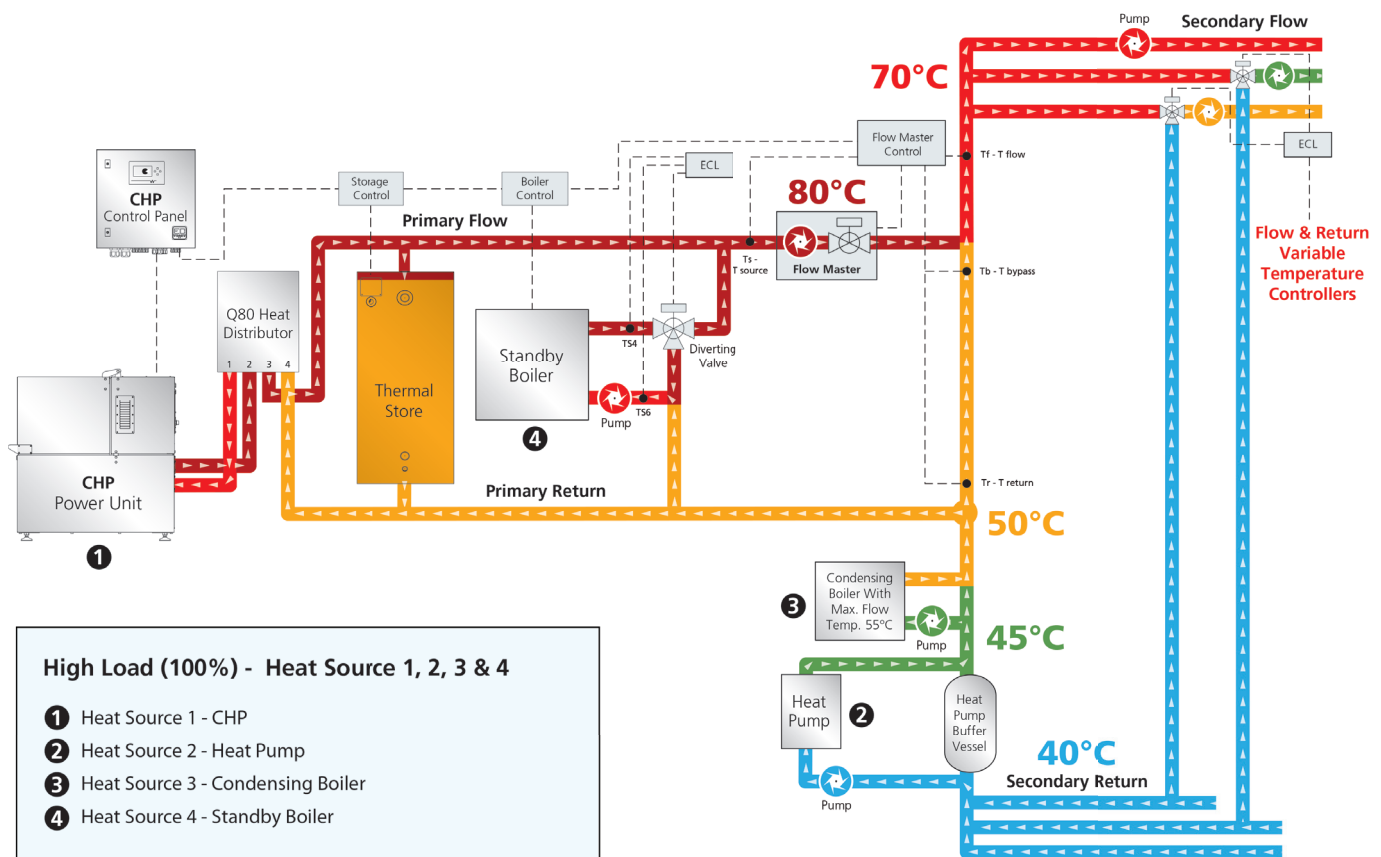
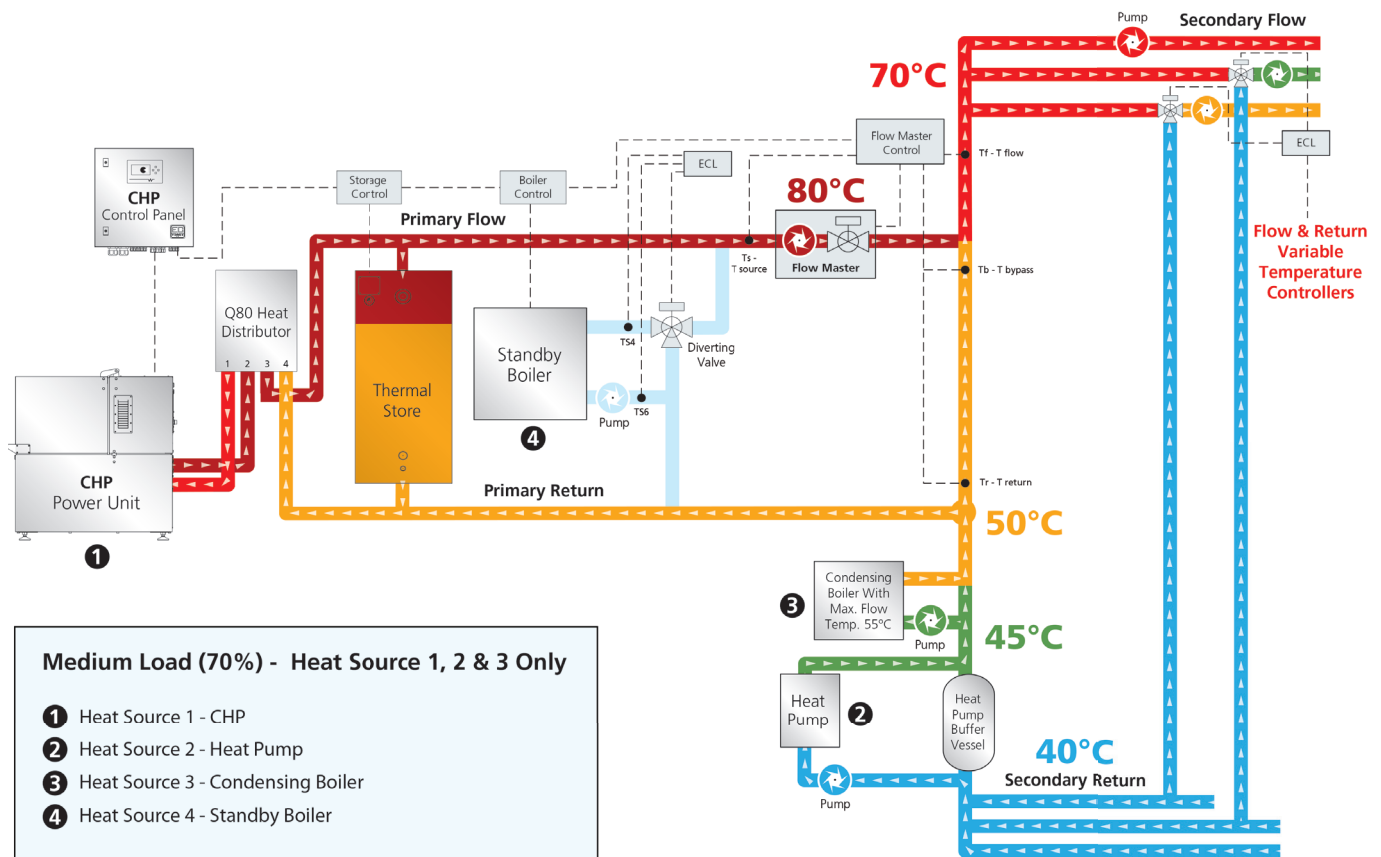

Figure 14: Heating system with LoadTracker CHP connected in parallel with boilers under varying load conditions

## ■ LoadTracker CHP - DESIGN GUIDE

---

In this configuration, it is important that LoadTracker CHP is prioritized over the boilers. For this reason the boilers, and also the heat pump, need to be controlled by the CHP control panel. LoadTracker then remains the primary source of heat and only when site demand exceeds CHP capacity, is the heat pump, condensing boiler and at last back-up boiler put in service. The start signal for these is generated by the control panel. The stand-by boiler is controlled by the Q-Network. In the case of multiple boilers, controls should be in a master / slave arrangement. The master boiler should be controlled from CHP control panel and in turn it should control subsequent boilers.

As flow from the back-up boiler can be diverted back to the storage vessel, its flow temperature has to be maintained at the desired value of 80°C. This is achieved by installing a temperature controlled modulating 3-port valve on the boiler circuit. Site flow temperature is controlled by Flow Master located on the main flow. The same parallel configuration can accommodate multiple LoadTracker CHP units, boilers and heat pumps.

The contents of the LoadTracker CHP thermal storage vessel are managed by the Q-Network storage control, which is based on a series of thermal probes placed along the side of the vessel. This vessel is designed to maintain a separation layer between the cooler return water at the bottom and the hot flow water at the top. As this intermediate layer moves vertically inside the storage vessel, its position is monitored by the probes. This information is interpreted in terms of site thermal demand by the LoadTracker CHP control panel. This produces the stop and start signals for all associated heat generators in a plant room.

During periods when site thermal demand ceases, the CHP thermal storage fills with hot water and LoadTracker CHP is kept on stand-by. This is the case, even with electricity demand being present. When site heat demand is re-established, the sequence of events is as follows:

In the first instance hot water is drawn through the top connection of the thermal storage vessel. As the CHP storage discharges this heat, the separation layer within the storage vessel moves up. When the thermal probes detect a sufficient change in the position of the separation layer, a start signal is sent to the power unit from the CHP control panel.

If site demand continues to be greater than CHP capacity, the storage vessel discharges more heat and the separation layer moves further up. A start signal is then generated for the heat pump and then pre-heating condensing boiler (if this has been specified as part of the Energy Centre).

If site heat demand is still not satisfied further heat is drawn out of the storage and the separation layer moves almost to the top of the storage vessel. A start signal is then generated to the stand-by boiler.

When site demand is satisfied, heat from boiler re-fills the storage vessel and the separation layer moves back down the vessel. As the change in position of the separation layer is detected by the probes, stop signals are sent consecutively to the stand-by boiler and heat pump or pre-heating condensing boiler. Only when the thermal storage is completely full of hot water *and* the sensor located in the heat distributor registers a high return temperature, will the LoadTracker CHP power unit be switched off and put on stand-by.

LoadTracker CHP 'learns' from varying site load patterns and its control system automatically optimises the choice of thermal probe which is to activate any instruction for stop/start. This constant re-evaluation and re-setting ensures that LoadTracker operating efficiency and storage capacity are maximised.

### **LoadTracker CHP with heat pumps**

Heat pumps can be incorporated into LoadTracker Energy Centres to gain even further reductions in site carbon footprint. As site-generated electricity from the CHP can be used for heat pumps, their operation becomes more cost effective. The combination of LoadTracker CHP and heat pump is ideally suited to site patterns involving low electrical and high thermal demand.

Selection of LoadTracker CHP unit numbers and heat pumps in an Energy Centre should be based on site demand profiles. One or more heat pumps can be connected to the return the first in line, as a means of pre-heating the return water. The methods of incorporating a heat pump into both series and parallel connections are shown in Figures 12, 13 and 14 above. In all cases, the heat pump should be controlled from the LoadTracker CHP control panel. Heat pumps should only be considered for sites where the return water temperature is less than 50°C. To obtain optimum heat pump performance, the heating circuit temperatures should be around 70°C for flow and 40°C for return.



## ■ LoadTracker CHP - DESIGN GUIDE

Relative to conventional heating based on 80°C flow / 70°C return, systems designed with 70°C flow / 40°C return can use larger heat emitters with smaller pipework. Reduced temperatures are ideal for buildings with underfloor heating, or where large-sized low temperature radiators are required.

Low return temperatures can also be achieved by systems based on multiple instantaneous water heaters (e.g. Danfoss FlatStation Heat Interface Units). This type of unit uses water from the heating circuit to produce domestic hot water instantaneously at the point of use. During intervals of hot water consumption, heating return temperature can be expected to fall below 25°C.

### 6.0 Installation

#### Electrical connections

LoadTracker CHP contains a mains-excited asynchronous generator. This means that the system is designed to operate in parallel with the grid and is excited by reactive power drawn from it. LoadTracker CHP cannot operate in island mode, so that in the event of a power cut the generator will cease to operate. Mains monitoring and protection relay (meeting respectively G83 or G59 requirements, depending on size of the CHP) is built into the control panel.

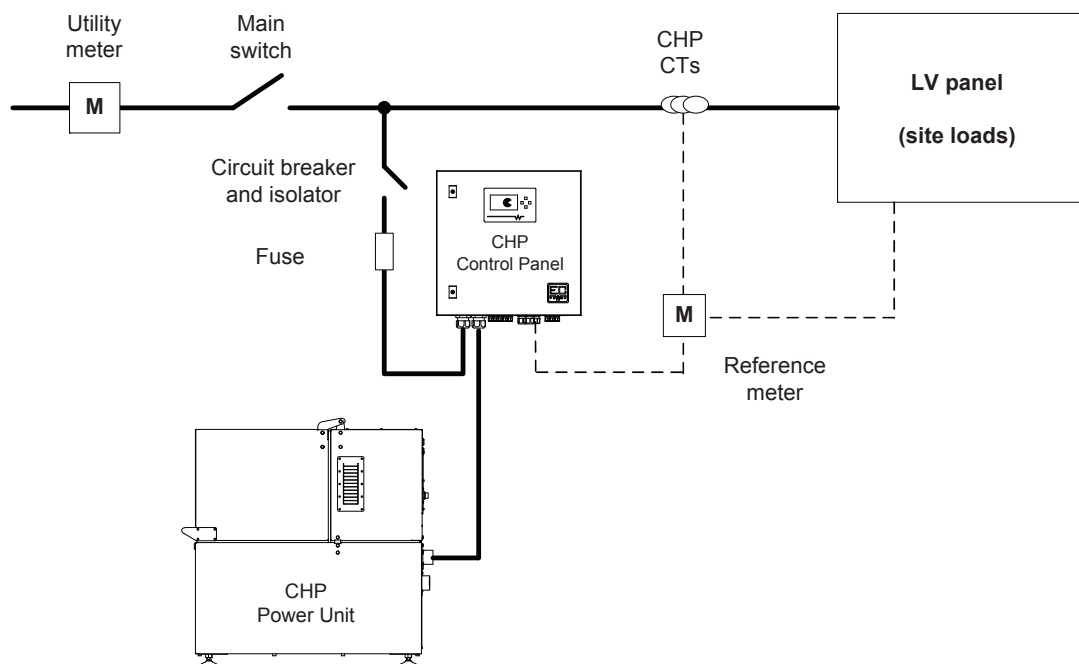

Figure 15: LoadTracker CHP electrical connections

LoadTracker CHP needs to be connected to a three phase, 400 V power supply. The connection is made at the main distribution board, just after the site utility meter. Furthermore, an additional reference meter for the CHP must be installed after this supply point, and before distribution is made to any consumer. The reference meter measures site demand and allows the CHP electricity output to be modulated in step with power demand. The connection cable from the mains to the CHP control panel must be fused to 32A for XRGI 6 and XRGI 9 and to 63A for XRGI 15 and XRGI 20.

Sites where electricity demand always exceeds LoadTracker CHP capacity may not require the electrical output to modulate. In this situation, a reference meter can be dispensed with.

Whenever it is economically viable, surplus electricity can be exported back to the grid. This option requires the installation of an export meter and needs to be agreed with the relevant electricity supplier.

## ■ LoadTracker CHP - DESIGN GUIDE

### Gas connections

LoadTracker CHP can operate on natural gas, LPG or biogas. Gas connections must be made in accordance with Gas Safe requirements.

	<b>kW/h (Gross Calorific Value)</b>	<b>m<sup>3</sup>/h</b>
<b>XRGI 6</b>	13 - 21	1.2 - 1.9
<b>XRGI 9</b>	19 - 32	1.7 - 3.0
<b>XRGI 15</b>	33 - 54	3.0 - 5.0
<b>XRGI 20</b>	41 - 67	3.7 - 6.1

Table 4: LoadTracker CHP systems gas consumption

Mains supply pressure of between 10 - 50 mbar can be accepted. The power unit is supplied with a flexible gas hose with internal thread connection: 1/2" for XRGI 6 and XRGI 9 and 3/4" for XRGI 15 and XRGI 20.

### Flue requirements

	<b>Temperature (max.)</b>	<b>Mass flow rate</b>	<b>Volumetric flow</b>
<b>XRGI 6</b>	100°C	40 kg/h (= 11.2 g/s)	44 m <sup>3</sup> /h (= 12 l/s)
<b>XRGI 9</b>	100°C	39 kg/h (= 10.8 g/s)	42 m <sup>3</sup> /h (= 12 l/s)
<b>XRGI 15</b>	120°C	95 kg/h (= 26.4 g/s)	109 m <sup>3</sup> /h (= 30 l/s)
<b>XRGI 20</b>	120°C	80 kg/h (= 22.2 g/s)	92 m <sup>3</sup> /h (= 26 l/s)

Table 5: LoadTracker CHP systems exhaust gases characteristics (operating on natural gas)

Back pressure of flue system should not exceed 100 mm water (= 10 mbar, or 1 kPa). The power unit under normal operation will switch off at about 200 mm but to keep proper margin flue system should be designed for < 100 mm. As during the engine start up there is a very short pressure peak of up to 5 kPa (50 mbar), LoadTracker CHP systems require H1 class flue. This is a pressure tightness class of up to 5 kPa.

There are no limits to the length of the flue system as long as back pressure is kept low enough – the diameter is big enough.

Due to temperature of the flue gases it is not uncommon for a considerable amount of condensate to collect in the flue. Adequate condensate collector must be installed to prevent running difficulties. Attention should be paid to a condensate collector (drain) as water may blow out when the engine starts, especially if flue is long and with high back pressure.

The power unit has 60 mm exhaust gas connection. The flue connection kit is supplied with each LoadTracker CHP.

## ■ LoadTracker CHP - DESIGN GUIDE

---

Multi system installation can have flue systems from all CHP's joined together. It is not recommended to join the CHP flue with a boiler flue.

Guidance on flue installation can be found in Gas Utilization Procedures IGE/UP/3 Edition 2 "Gas fuelled spark ignition and dual fuel engines" and IGE/UP/10 Edition 3 "Installation of flued gas appliances in industrial and commercial premises".

Flue terminations must comply with the current building regulations and local authority requirements.

### **Ventilation requirements**

LoadTracker CHP takes combustion air from a plant room. XRGI 6 / XRGI 9 require a minimum air intake of 800 litres/minute and XRGI 15 / XRGI 20 requires 1650 litres/minute.

The ventilation provisions need to be calculated in accordance to British Standards (BS) 6644:2011 for non-domestic installations.

The high and low level ventilation should be direct to outside air on the same wall. The vertical distance between high and low level ventilation should be as great as possible to achieve convection airflow.

# LoadTracker CHP - DESIGN GUIDE

## APPENDIX (i) - LoadTracker XRGi 6 data sheet

### TECHNICAL DATA FOR THE XRGi® 6

Product data sheet in accordance with Regulation (EU) No. 811/2013, Dated 26.09.2015

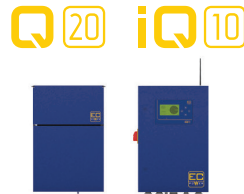

The XRGi® is a combined heat and power plant (CHP) that works on the principle of cogeneration.

An XRGi® system consists of three main components – the Power Unit, Q-Heat Distributor and the iQ-Control Panel. In a package with a Flow Master (temperature control, class II = 2 %) the XRGi® is rated as seasonal space heating energy efficiency class A++.

In addition, you can also extend your XRGi® system with a storage tank with a capacity of 500, 800 or 1,000 litres for optimum operation.

#### ORDERING DATA

Supplier's name or trademark	EC POWER	
	XRGi® 6 without condensing technology <sup>1</sup>	XRGi® 6 with condensing technology <sup>1</sup>
Supplier's model identifier	X060001	X060001+01KIT2616
Article number	Power Unit, iQ10-Control Panel, Q20-Heat Distributor	Power Unit, iQ10-Control Panel, Q20-Heat Distributor + Condensing and exhaust gas heat exchanger kit
Modules		

#### ErP-LABEL DATA<sup>2</sup>

Seasonal space heating energy efficiency class	<b>A++</b>	<b>A++</b>
Rated heat output $P_{rated}$	12 kW	13 kW
Seasonal space heating energy efficiency; $H_s$	<b>178 %</b>	<b>193 %</b>
Sound power level, indoors $L_{WA}$	63 dB	63 dB
Electrical efficiency; in accordance with heating value $H_i$ $\eta_{el\ CHP100+SUP.0}$	31 %	31 %
All special precautions to be taken during assembly, installation or service	Refer to Commissioning and Service Manual	Refer to Commissioning and Service Manual

<sup>1</sup> Return temperatures as per EN 50465 2015 7.6.1: Without condensing technology 47 °C, with condensing technology 30 °C.

<sup>2</sup> The values were rounded in accordance with the requirements governing product data sheets by Regulation (EU) No. 811/2013.

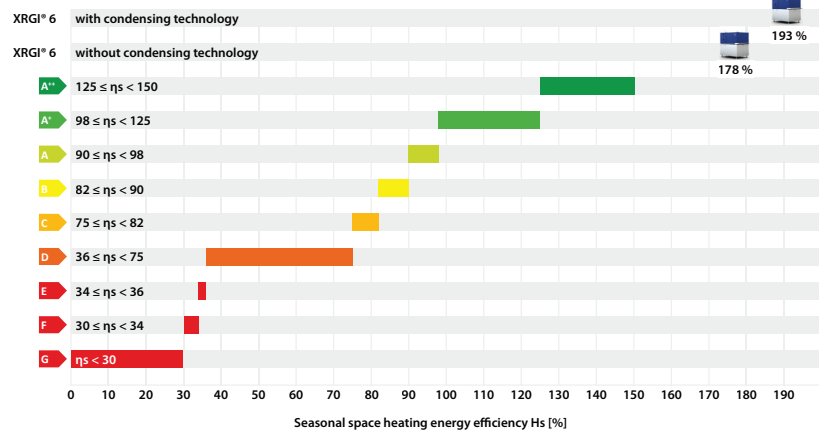
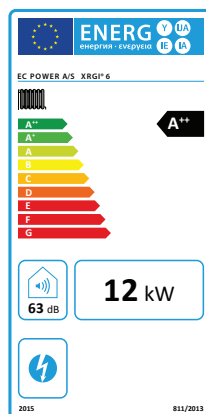

# LoadTracker CHP - DESIGN GUIDE

## APPENDIX (i) - LoadTracker XRGI 6 data sheet

### OUTPUT

XRGI® system		XRGI® 6 without condensing technology <sup>1</sup>			XRGI® 6 with condensing technology <sup>1</sup>		
Power modulation*		50 %	75 %	100 %	50 %	75 %	100 %
Electrical output, modulating*	kW	3.0	4.5	6.0	3.0	4.5	6.0
Thermal output, modulating*	kW	8.2	10.1	12.2	9.0	11.1	13.3
Power consumption, gas in accordance with Hi	kW	11.9	15.5	19.4	12.1	15.6	19.4
Electrical own demand, production	kW	0.035	0.035	0.035	0.035	0.035	0.035
Electrical own demand, stand-by	kW	0.024			0.024		

### EFFICIENCIES & OPERATING PARAMETERS

Power modulation*		50 %	75 %	100 %	50 %	75 %	100 %
Electrical efficiency in accordance with Hi	%	25.0	28.8	30.6	24.8	28.7	30.5
Thermal efficiency in accordance with Hi	%	68.6	64.8	63.0	74.4	71.0	68.5
Total efficiency in accordance with Hi	%	93.6	93.6	93.6	99.2	99.6	98.9
Seasonal space heating energy efficiency in operating mode <sup>2,3</sup>	$\eta_{son}$ %	182			197		

### POWER MODULATION

#### Continuous modulation of 2,5 – 6 kW in power-controlled mode

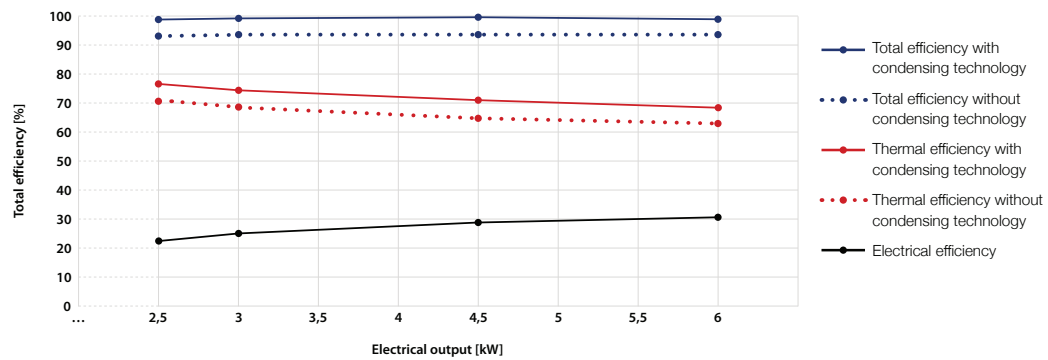

### TOTAL EFFICIENCY AT FULL LOAD

#### XRGI® 6 total efficiency / return temperature

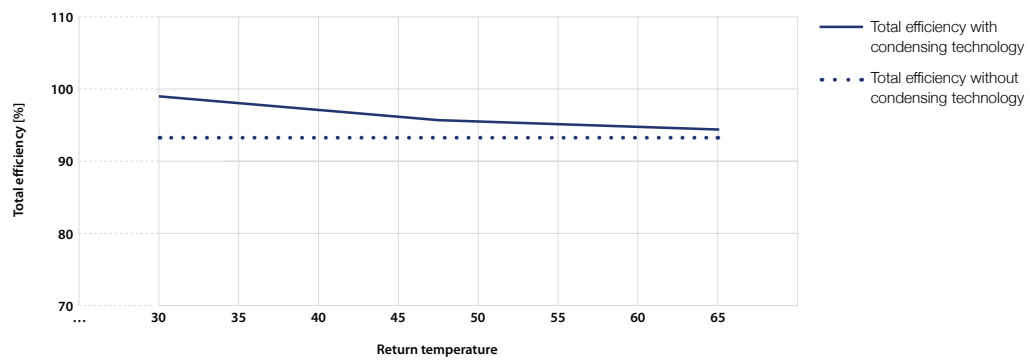

\* Continuous modulation in power-controlled mode

<sup>1</sup> Return temperatures as per EN 50465 2015 7.6.1: Without condensing technology 47 °C, with condensing technology 30 °C.

<sup>2</sup> Based on the values measured by the Danish Gas technology Center and accredited independent third-party organisations.

<sup>3</sup> Efficiency at rated heat output as per the delegated Commission Regulation (EU) No. 811/2013

# LoadTracker CHP - DESIGN GUIDE

## APPENDIX (i) - LoadTracker XRGI 6 data sheet

### HYDRAULIC INTEGRATION

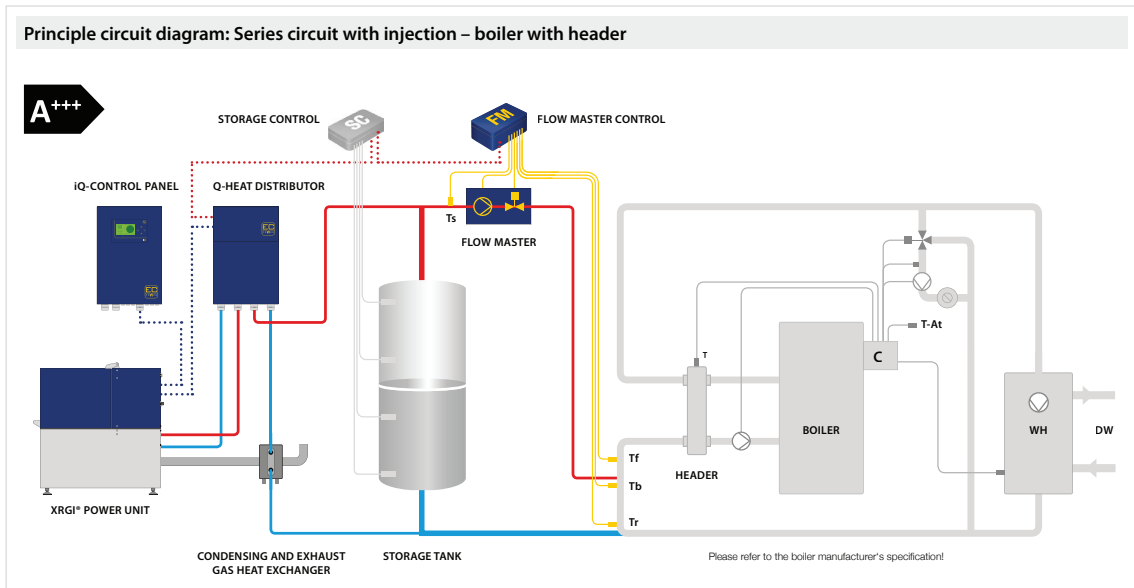

More principle circuit diagrams and information can be found in the EC POWER „Hydraulic Solutions“.

**NOTE:**

If products from other companies are used in the system in addition to EC Power products, EC Power assumes no liability for the accuracy of the energy efficiency class calculation for the entire system.

XRGI® system			XRGI® 6 without condensing technology <sup>1</sup>		XRGI® 6 with condensing technology <sup>1</sup>	
Flow temperature, constant	°C		~ 80		~ 80	
Return temperature, variable	°C		5-70		5-70	

**FUELS**

Natural gas (all qualities), propane, butane	yes	yes
--	-----	-----

**EXHAUST GAS**

Power modulation		50 %	75 %	100 %	50 %	75 %	100 %
Max. exhaust gas temperature	°C	-	-	100	-	-	90
Condensate	kg/h	-	-	-	1.2	1.4	1.5
Emissions (test data)	CO < 150	mg/Nm <sup>3</sup>	-	-	12	-	-
	NOx < 350	mg/Nm <sup>3</sup>	-	-	319	-	-

**SOUND**

Sound pressure level at a distance of up to 1 m (based on surroundings)	dB(A)	49
---	-------	----

**POWER CONNECTION**

Voltage, 3 phases + N + Earth	V	400
Frequency	Hz	50

**SERVICE**

Service interval (operating hours)	Hours	10,000
------------------------------------	-------	--------

**DIMENSIONS AND WEIGHT**

		XRGI® 6 Power Unit	Q20-Heat Distributor	iQ10-Control Panel
Dimensions, W x H x D	mm	640 x 960 x 920	400 x 600 x 195	400 x 600 x 210
Footprint	m <sup>2</sup>	0.59	wall mounted	wall mounted
Weight	kg	440	25	30

All values are net and have been certified by an independent inspection body. Tolerance ±5 %. Specifications subject to change without notice.

# LoadTracker CHP - DESIGN GUIDE

## APPENDIX (i) - LoadTracker XRGI 6 data sheet

### TECHNICAL DATA FOR THE XRGI® 6 WITH FLOW MASTER

(Temperature control, Class II = 2 %)

Product data sheet in accordance with Regulation (EU) No. 811/2013, Dated 26.09.2015



Q20 IQ10 FM



Figure shows FM type 350



The Flow Master including Flow Master Control regulates the supply of heat from the XRGI® and from the storage tank to the consumer network. This technology enables a significantly higher heat output to be temporarily made available to the consumer side. This allows peaks of heat demand to be handled by the XRGI®, thereby extending its service life and increasing electricity production.

The 4 models can deliver a heat output of 50, 150, 250 or 350 at a ΔT of 20 K.

#### ORDERING DATA

Supplier's name or trademark	EC POWER			
Supplier's model identifier	XRGI' 6 without condensing technology <sup>1</sup>		XRGI' 6 with condensing technology <sup>1</sup>	
Article number	X060001		X060001+01KIT2616	
Modules	Power Unit, IQ10-Control Panel, Q20-Heat Distributor		Power Unit, IQ10-Control Panel, Q20-Heat Distributor + Condensing and exhaust gas heat exchanger kit	
Supplier's model identifier	Flow Master including Flow Master Control			
FM-type (Temperature control, Class II = 2 %)	FM 50	FM 150	FM 250	FM 350
Article number	17D1130	17D1131	17D1132	17D1133

#### ErP-LABEL DATA<sup>2</sup>

Seasonal space heating energy efficiency class of package	A+++	
Seasonal space heating energy efficiency of package	180 %	195 %

<sup>1</sup> Return temperatures as per EN 50465 2015 7.6.1: Without condensing technology 47 °C, with condensing technology 30 °C.  
<sup>2</sup> The values were rounded in accordance with the requirements governing product data sheets by Regulation (EU) No. 811/2013.

Seasonal space heating energy efficiency of the space heater with cogeneration	178 %
Temperature control	Class I = 1 %, Class II = 2 %, Class III = 1,5 %, Class IV = 2 %, Class V = 3 %, Class VI = 4 %, Class VII = 3,5 %, Class VIII = 5 %
Supplementary boiler	Seasonal space heating energy efficiency in %
Solar contribution (From fiche of solar device)	( 'III' x [ ] + 'IV' x [ ] ) x 0,7 x ( [ ] / 100 ) x [ ] = + [ ] %
Seasonal space heating energy efficiency of package	180 %
Seasonal space heating energy class of package	G F E D C B A A+ A++ A+++

The energy efficiency of the package of products provided for in this fiche may not correspond to its actual energy efficiency once installed in a building, as this efficiency is influenced by further factors such as heat loss in the distribution system and the dimensioning of the products in relation to building size and characteristics.

# LoadTracker CHP - DESIGN GUIDE

## APPENDIX (ii) - LoadTracker XRGi 9 data sheet

### TECHNICAL DATA FOR THE XRGi® 9

Product data sheet in accordance with Regulation (EU) No. 811/2013, Dated 26.09.2015



The XRGi® is a combined heat and power plant (CHP) that works on the principle of cogeneration.

An XRGi® system consists of three main components – the Power Unit, Q-Heat Distributor and the iQ-Control Panel. In a package with a Flow Master (temperature control, class II = 2 %) the XRGi® is rated as seasonal space heating energy efficiency class A++.

In addition, you can also extend your XRGi® system with a storage tank with a capacity of 500, 800 or 1,000 litres for optimum operation.

#### ORDERING DATA

Supplier's name or trademark	EC POWER	
Supplier's model identifier	<b>XRGi' 9 without condensing technology<sup>1</sup></b>	<b>XRGi' 9 with condensing technology<sup>1</sup></b>
Article number	X090001	X090001+01KIT2616
Modules	Power Unit, iQ10-Control Panel, Q20-Heat Distributor	Power Unit, iQ10-Control Panel, Q20-Heat Distributor + Condensing and exhaust gas heat exchanger kit

#### ErP-LABEL DATA<sup>2</sup>

Seasonal space heating energy efficiency class	<b>A++</b>	<b>A++</b>
Rated heat output P <sub>rated</sub>	19 kW	21 kW
Seasonal space heating energy efficiency; H <sub>s</sub> η <sub>s</sub>	<b>181 %</b>	<b>206 %</b>
Sound power level, indoors L <sub>WA</sub>	63 dB	63 dB
Electrical efficiency; in accordance with heating value Hi η <sub>el</sub> CHP100+SUP.0	30 %	31 %
All special precautions to be taken during assembly, installation or service	Refer to Commissioning and Service Manual	Refer to Commissioning and Service Manual

<sup>1</sup> Return temperatures as per EN 50465 2015 7.6.1: Without condensing technology 47 °C, with condensing technology 30 °C.  
<sup>2</sup> The values were rounded in accordance with the requirements governing product data sheets by Regulation (EU) No. 811/2013.

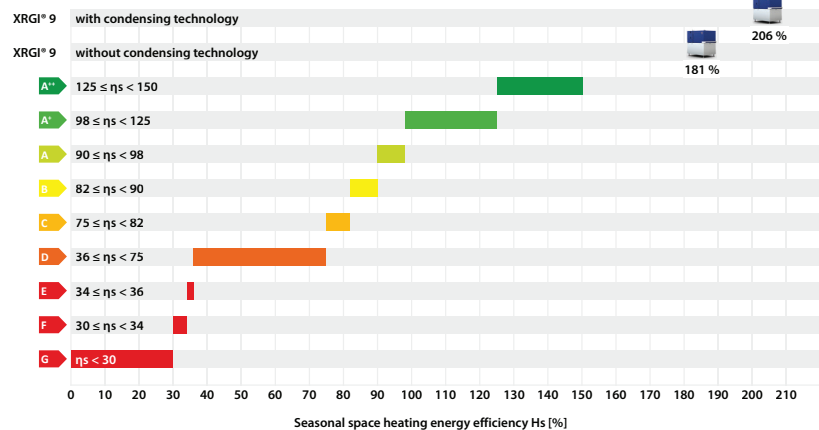
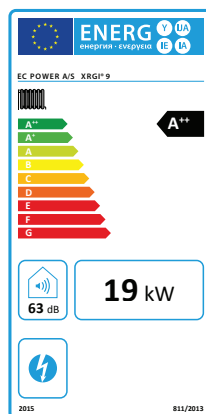



# LoadTracker CHP - DESIGN GUIDE

## APPENDIX (ii) - LoadTracker XRGI 9 data sheet

### OUTPUT

XRGI® system		XRGI® 9 without condensing technology <sup>1</sup>			XRGI® 9 with condensing technology <sup>1</sup>		
Power modulation*		50 %	75 %	100 %	50 %	75 %	100 %
Electrical output, modulating*	kW	4.5	6.8	9.0	4.5	6.8	9.0
Thermal output, modulating*	kW	12.0	15.4	19.2	13.5	17.2	21.3
Power consumption, gas in accordance with Hi	kW	17.3	23.2	29.5	17.2	23.1	29.3
Electrical own demand, production	kW	0.101	0.100	0.099	0.102	0.101	0.100
Electrical own demand, stand-by	kW		0.024			0.024	

### EFFICIENCIES & OPERATING PARAMETERS

Power modulation*		50 %	75 %	100 %	50 %	75 %	100 %
Electrical efficiency in accordance with Hi	%	25.9	29.3	30.4	25.9	29.4	30.6
Thermal efficiency in accordance with Hi	%	69.6	66.1	64.9	78.5	74.4	72.7
Total efficiency in accordance with Hi	%	95.4	95.4	95.3	104.3	103.7	103.3
Seasonal space heating energy efficiency in operating mode <sup>2,3</sup>	$\eta_{\text{son}}$ %		186			211	

### POWER MODULATION

#### Continuous modulation of 4 – 9 kW in power-controlled mode

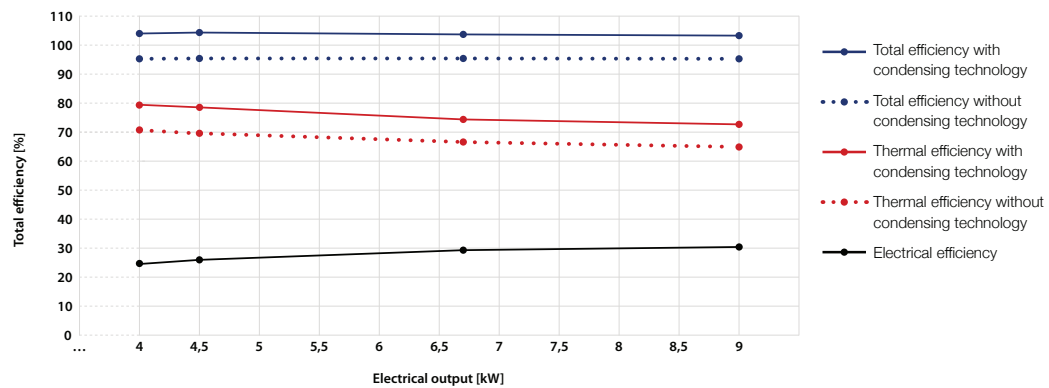

### TOTAL EFFICIENCY AT FULL LOAD

#### XRGI® 9 total efficiency / return temperature

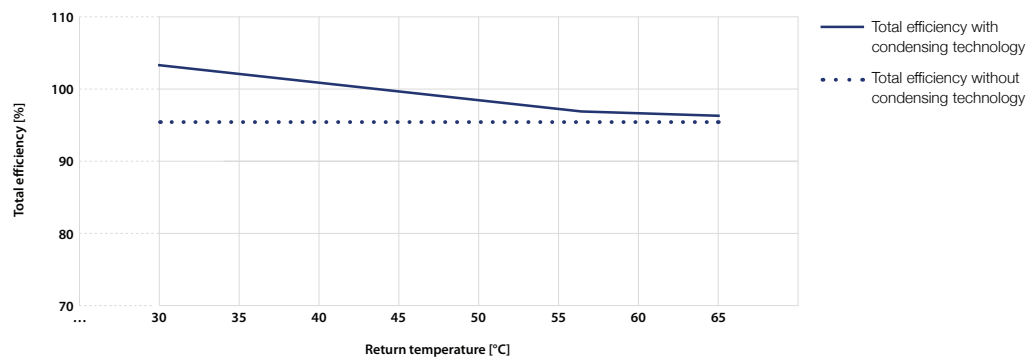

\* Continuous modulation in power-controlled mode

<sup>1</sup> Return temperatures as per EN 50465 2015 7.6.1: Without condensing technology 47 °C, with condensing technology 30 °C.

<sup>2</sup> Based on the values measured by the Danish Gas technology Center and accredited independent third-party organisations.

<sup>3</sup> Efficiency at rated heat output as per the delegated Commission Regulation (EU) No. 811/2013

# LoadTracker CHP - DESIGN GUIDE

## APPENDIX (ii) - LoadTracker XRGI 9 data sheet

### HYDRAULIC INTEGRATION

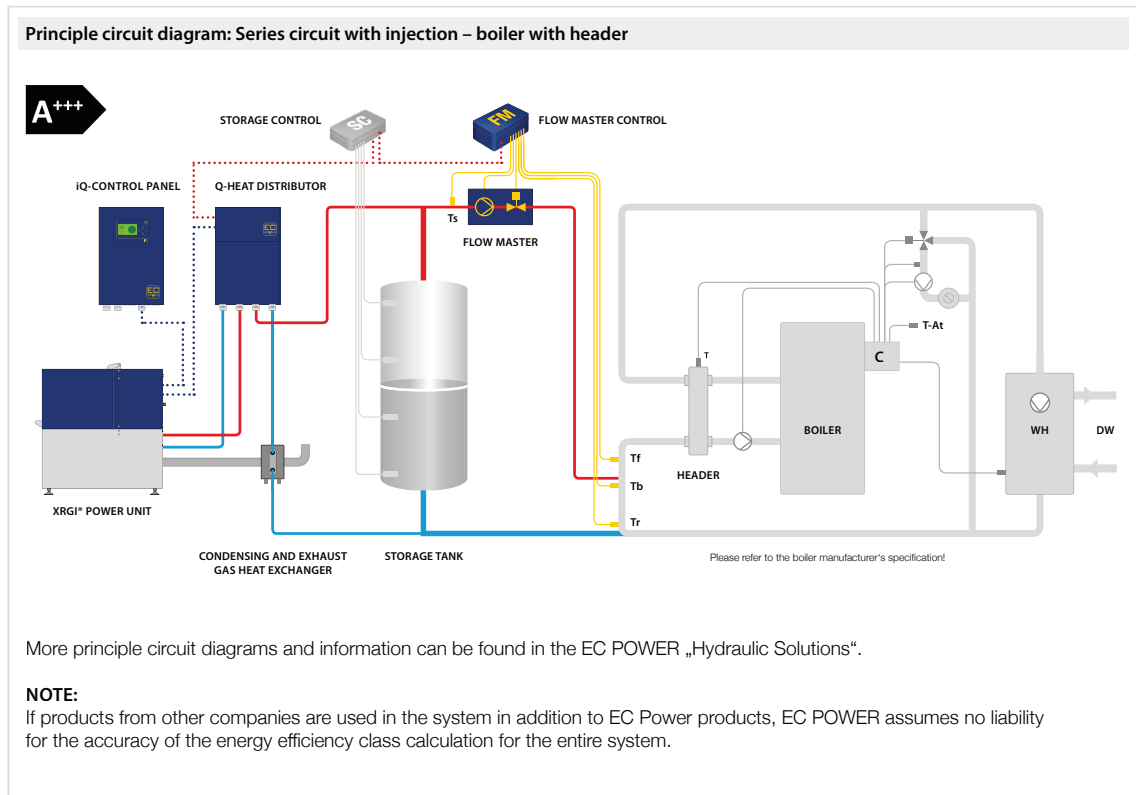

XRGI® system			XRGI® 9 without condensing technology <sup>1</sup>		XRGI® 9 with condensing technology <sup>1</sup>	
Flow temperature, constant	°C		~ 80		~ 80	
Return temperature, variable	°C		5-70		5-70	

<b>FUELS</b>	Natural gas (all qualities), propane, butane	yes	yes
--------------	--	-----	-----

EXHAUST GAS			50 %	75 %	100 %	50 %	75 %	100 %
Power modulation								
Max. exhaust gas temperature	°C		-	-	100	-	-	90
Condensate	kg/h		-	-	-	1.9	2.3	2.6
Emissions (test data)	CO < 70	mg/Nm <sup>3</sup>	-	-	52	-	-	55
	NOx < 100	mg/Nm <sup>3</sup>	-	-	52	-	-	54

<b>SOUND</b>	Sound pressure level at a distance of up to 1 m (based on surroundings)	dB(A)	49
--------------	---	-------	----

<b>POWER CONNECTION</b>	Voltage, 3 phases + N + Earth	V	400
	Frequency	Hz	50

<b>SERVICE</b>	Service interval (operating hours)	Hours	10,000
----------------	------------------------------------	-------	--------

DIMENSIONS AND WEIGHT			XRGI® 9 Power Unit	Q20-Heat Distributor	iQ10-Control Panel
Dimensions, W x H x D	mm		640 x 960 x 920	400 x 600 x 195	400 x 600 x 210
Footprint	m <sup>2</sup>		0.59	wall mounted	wall mounted
Weight	kg		440	25	30

All values are net and have been certified by an independent inspection body. Tolerance ±5 %. Specifications subject to change without notice.

# LoadTracker CHP - DESIGN GUIDE

## APPENDIX (ii) - LoadTracker XRGi 9 data sheet

### TECHNICAL DATA FOR THE XRGi® 9 WITH FLOW MASTER

(Temperature control, Class II = 2 %)

Product data sheet in accordance with Regulation (EU) No. 811/2013, Dated 26.09.2015



Q20 IQ10 FM



Figure shows FM type 350



The Flow Master including Flow Master Control regulates the supply of heat from the XRGi® and from the storage tank to the consumer network. This technology enables a significantly higher heat output to be temporarily made available to the consumer side. This allows peaks of heat demand to be handled by the XRGi®, thereby extending its service life and increasing electricity production.

The 4 models can deliver a heat output of 50, 150, 250 or 350 at a ΔT of 20 K.

#### ORDERING DATA

Supplier's name or trademark	EC POWER			
Supplier's model identifier	XRGi' 9 without condensing technology <sup>1</sup>		XRGi' 9 with condensing technology <sup>1</sup>	
Article number	X090001		X090001+01KIT2616	
Modules	Power Unit, IQ10-Control Panel, Q20-Heat Distributor		Power Unit, IQ10-Control Panel, Q20-Heat Distributor + Condensing and exhaust gas heat exchanger kit	
Supplier's model identifier	Flow Master including Flow Master Control			
FM-type (Temperature control, Class II = 2 %)	FM 50	FM 150	FM 250	FM 350
Article number	17D1130	17D1131	17D1132	17D1133

#### ErP-LABEL DATA<sup>2</sup>

Seasonal space heating energy efficiency class of package	A+++	
Seasonal space heating energy efficiency of package	183 %	208 %

<sup>1</sup> Return temperatures as per EN 50465 2015 7.6.1: Without condensing technology 47 °C, with condensing technology 30 °C.  
<sup>2</sup> The values were rounded in accordance with the requirements governing product data sheets by Regulation (EU) No. 811/2013.

Seasonal space heating energy efficiency of the space heater with cogeneration	181 %
Temperature control	Class I = 1 %, Class II = 2 %, Class III = 1,5 %, Class IV = 2 %, Class V = 3 %, Class VI = 4 %, Class VII = 3,5 %, Class VIII = 5 %
Supplementary boiler	Seasonal space heating energy efficiency in %
Solar contribution (From fiche of solar device)	( 'III' x [ ] + 'IV' x [ ] ) x 0,7 x ( [ ] / 100 ) x [ ] = + [ ] %
Seasonal space heating energy efficiency of package	183 %
Seasonal space heating energy efficiency class of package	G F E D C B A A+ A++ A+++

The energy efficiency of the package of products provided for in this fiche may not correspond to its actual energy efficiency once installed in a building, as this efficiency is influenced by further factors such as heat loss in the distribution system and the dimensioning of the products in relation to building size and characteristics.

# LoadTracker CHP - DESIGN GUIDE

## APPENDIX (iii) - LoadTracker XRGI 15 data sheet

### TECHNICAL DATA FOR THE XRGI® 15

Product data sheet in accordance with Regulation (EU) No. 811/2013, Dated 26.09.2015



The XRGI® is a combined heat and power plant (CHP) that works on the principle of cogeneration.

An XRGI® system consists of three main components – the Power Unit, Q-Heat Distributor and the iQ-Control Panel. In a package with a Flow Master (temperature control, class II = 2 %) the XRGI® is rated as seasonal space heating energy efficiency class A++.

In addition, you can also extend your XRGI® system with a storage tank with a capacity of 500, 800 or 1,000 litres for optimum operation.

#### ORDERING DATA

Supplier's name or trademark	EC POWER	
Supplier's model identifier	<b>XRGI® 15 without condensing technology<sup>1</sup></b>	<b>XRGI® 15 with condensing technology<sup>1</sup></b>
Article number	X150001	X150001+01KIT2616
Modules	Power Unit, iQ15-Control Panel, Q80-Heat Distributor	Power Unit, iQ15-Control Panel, Q80-Heat Distributor + Condensing and exhaust gas heat exchanger kit

#### ErP-LABEL DATA<sup>2</sup>

Seasonal space heating energy efficiency class	<b>A++</b>	<b>A++</b>
Rated heat output $P_{rated}$	31 kW	33 kW
Seasonal space heating energy efficiency; $H_s$	<b>174 %</b>	<b>189 %</b>
Sound power level, indoors $L_{WA}$	67 dB	67 dB
Electrical efficiency; in accordance with heating value $H_i$ $\eta_{el\ CHP100+SUP.0}$	31 %	31 %
All special precautions to be taken during assembly, installation or service	Refer to Commissioning and Service Manual	Refer to Commissioning and Service Manual

<sup>1</sup> Return temperatures as per EN 50465 2015 7.6.1: Without condensing technology 47 °C, with condensing technology 30 °C.  
<sup>2</sup> The values were rounded in accordance with the requirements governing product data sheets by Regulation (EU) No. 811/2013.

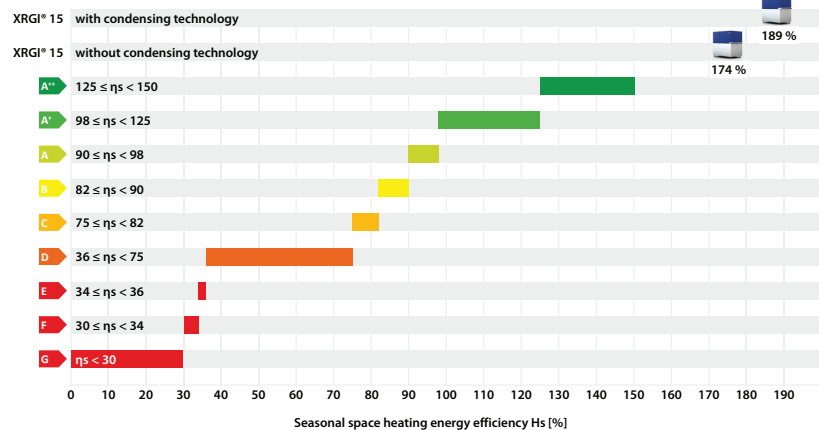
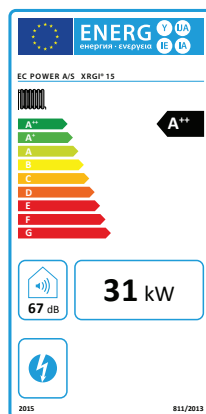

# LoadTracker CHP - DESIGN GUIDE

## APPENDIX (iii) - LoadTracker XRGI 15 data sheet

### OUTPUT

XRGI® system		XRGI® 15 without condensing technology <sup>1</sup>			XRGI® 15 with condensing technology <sup>1</sup>		
Power modulation*		50 %	75 %	100 %	50 %	75 %	100 %
Electrical output, modulating*	kW	7.5	11.3	15.0	7,5	11.3	15.0
Thermal output, modulating*	kW	20.6	25.8	30.6	22,3	28.0	33.1
Power consumption, gas in accordance with Hi	kW	30.0	40.0	49.5	30,0	40.0	49.5
Electrical own demand, production	kW	0.054	0.056	0.056	0,056	0.056	0.056
Electrical own demand, stand-by	kW		0.025			0.025	

### EFFICIENCIES & OPERATING PARAMETERS

Power modulation*		50 %	75 %	100 %	50 %	75 %	100 %
Electrical efficiency in accordance with Hi	%	25.0	28.1	30.5	25.0	28.1	30.5
Thermal efficiency in accordance with Hi	%	68.7	64.5	61.8	74.3	70.0	66.9
Total efficiency in accordance with Hi	%	93.7	92.6	92.3	99.3	98.1	97.4
Seasonal space heating energy efficiency in operating mode <sup>2,3</sup>	$\eta_{\text{son}}$ %		178			193	

### POWER MODULATION

#### Continuous modulation of 6 – 15 kW in power-controlled mode

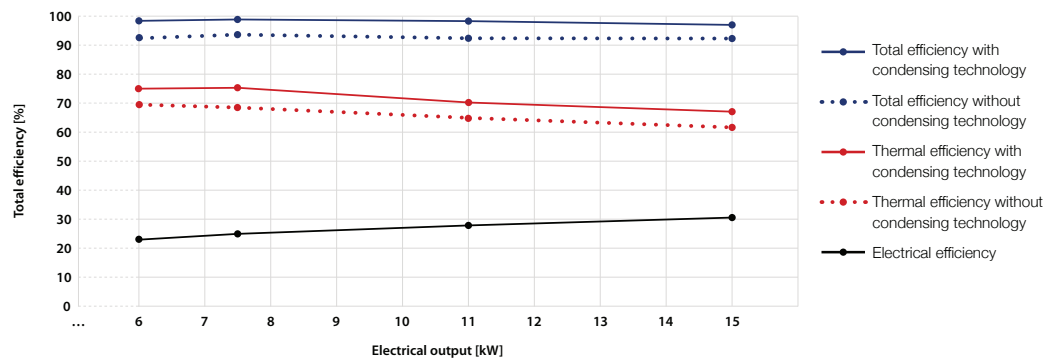

### TOTAL EFFICIENCY AT FULL LOAD

#### XRGI® 15 total efficiency / return temperature

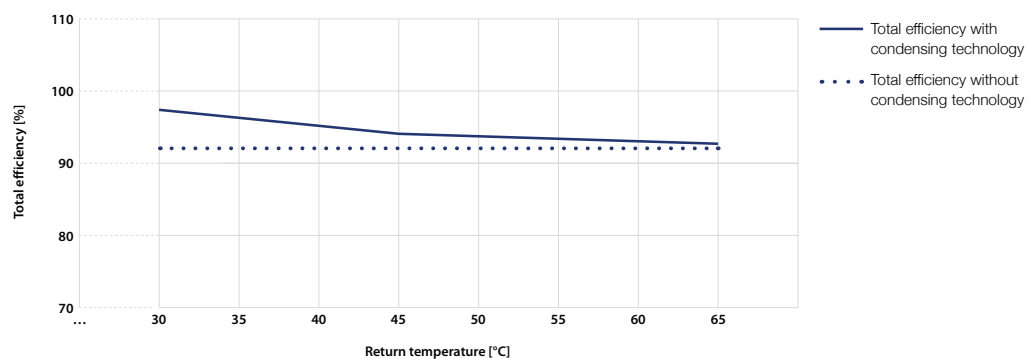

\* Continuous modulation in power-controlled mode

<sup>1</sup> Return temperatures as per EN 50465 2015 7.6.1: Without condensing technology 47 °C, with condensing technology 30 °C.

<sup>2</sup> Based on the values measured by the Danish Gas technology Center and accredited independent third-party organisations.

<sup>3</sup> Efficiency at rated heat output as per the delegated Commission Regulation (EU) No. 811/2013

# LoadTracker CHP - DESIGN GUIDE

## APPENDIX (iii) - LoadTracker XRGI 15 data sheet

### HYDRAULIC INTEGRATION

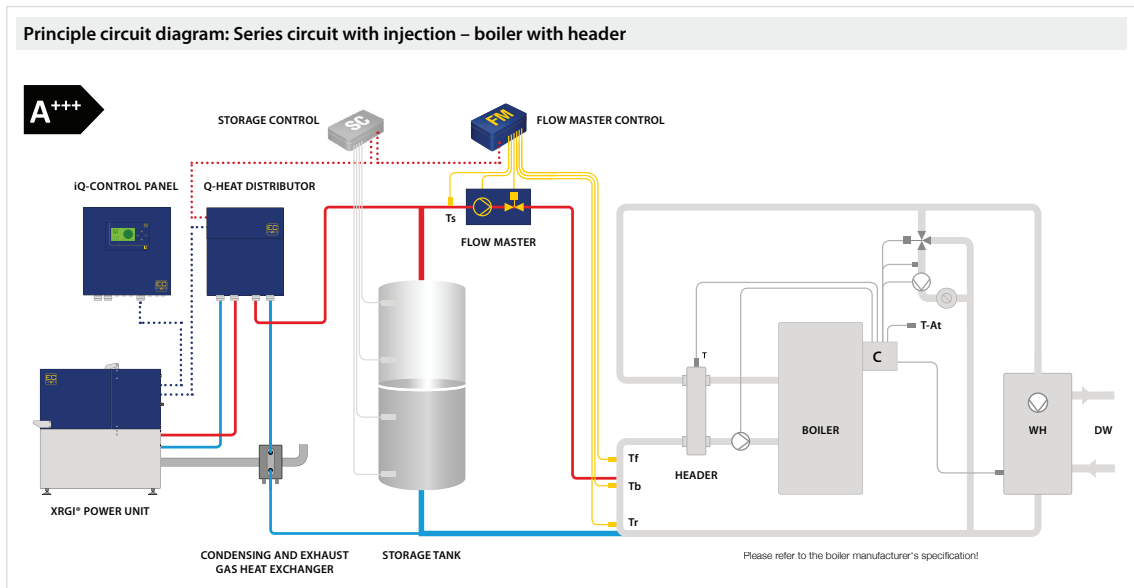

More principle circuit diagrams and information can be found in the EC POWER „Hydraulic Solutions“.

**NOTE:**

If products from other companies are used in the system in addition to EC Power products, EC Power assumes no liability for the accuracy of the energy efficiency class calculation for the entire system.

XRGI <sup>®</sup> system		XRGI <sup>®</sup> 15 without condensing technology <sup>1</sup>	XRGI <sup>®</sup> 15 with condensing technology <sup>1</sup>
Flow temperature, constant	°C	~ 85	~ 85
Return temperature, variable	°C	5-75	5-75

### FUELS

Natural gas (all qualities), propane, butane	yes	yes
--	-----	-----

### EXHAUST GAS

Power modulation		50 %	75 %	100 %	50 %	75 %	100 %	
Max. exhaust gas temperature	°C	-	-	120	-	-	90	
Condensate	kg/h	-	-	-	2.0	1.9	1.9	
Emissions (test data)	CO < 150	mg/Nm <sup>3</sup>	-	-	99	-	-	97
	NOx < 350	mg/Nm <sup>3</sup>	-	-	293	-	-	290

### SOUND

Sound pressure level at a distance of up to 1 m (based on surroundings)	dB(A)	53
---	-------	----

### POWER CONNECTION

Voltage, 3 phases + N + Earth	V	400
Frequency	Hz	50

### SERVICE

Service interval (operating hours)	Hours	8,500
------------------------------------	-------	-------

### DIMENSIONS AND WEIGHT

		XRGI <sup>®</sup> 15 Power Unit	Q80-Heat Distributor	iQ15-Control Panel
Dimensions, W x H x D	mm	750 x 1,170 x 1,250	550 x 600 x 295	600 x 600 x 210
Footprint	m <sup>2</sup>	0.93	wall mounted	wall mounted
Weight	kg	700	44	40

All values are net and have been certified by an independent inspection body. Tolerance ±5 %. Specifications subject to change without notice.

# LoadTracker CHP - DESIGN GUIDE

## APPENDIX (iii) - LoadTracker XRGI 15 data sheet

### TECHNICAL DATA FOR THE XRGI® 15 WITH FLOW MASTER

(Temperature control, Class II = 2 %)

Product data sheet in accordance with Regulation (EU) No. 811/2013, Dated 26.09.2015



Q80 IQ15 FM



Figure shows FM type 350



The Flow Master including Flow Master Control regulates the supply of heat from the XRGI® and from the storage tank to the consumer network. This technology enables a significantly higher heat output to be temporarily made available to the consumer side. This allows peaks of heat demand to be handled by the XRGI®, thereby extending its service life and increasing electricity production.

The 4 models can deliver a heat output of 50, 150, 250 or 350 at a ΔT of 20 K.

#### ORDERING DATA

Supplier's name or trademark	EC POWER			
Supplier's model identifier	XRGI' 15 without condensing technology <sup>1</sup>		XRGI' 15 with condensing technology <sup>1</sup>	
Article number	X150001		X150001+01KIT2616	
Modules	Power Unit, IQ15-Control Panel, Q80-Heat Distributor		Power Unit, IQ15-Control Panel, Q80-Heat Distributor + Condensing and exhaust gas heat exchanger kit	
Supplier's model identifier	Flow Master including Flow Master Control			
FM-type (Temperature control, Class II = 2 %)	FM 50	FM 150	FM 250	FM 350
Article number	17D1130	17D1131	17D1132	17D1133

#### ErP-LABEL DATA<sup>2</sup>

Seasonal space heating energy efficiency class of package	A+++	
Seasonal space heating energy efficiency of package	176 %	191 %

<sup>1</sup> Return temperatures as per EN 50465 2015 7.6.1: Without condensing technology 47 °C, with condensing technology 30 °C.  
<sup>2</sup> The values were rounded in accordance with the requirements governing product data sheets by Regulation (EU) No. 811/2013.

Seasonal space heating energy efficiency of the space heater with cogeneration: 174 %

Temperature control: Class I = 1 %, Class II = 2 %, Class III = 1,5 %, Class IV = 2 %, Class V = 3 %, Class VI = 4 %, Class VII = 3,5 %, Class VIII = 5 %, + 2 %

Supplementary boiler: Seasonal space heating energy efficiency in %  
 ( ) - 'I' x 'II' = - %

Solar contribution (From fiche of solar device):  
 Collector size (in m<sup>2</sup>) x Tank volume (in m<sup>3</sup>) x Collector efficiency (in %) x Tank rating (A<sup>+</sup> = 0,95, A = 0,91, B = 0,86, C = 0,83, D-G = 0,81) = + %

Seasonal space heating energy efficiency of package: 176 %

Seasonal space heating energy efficiency class of package: G, F, E, D, C, B, A, A+, A++, A+++

< 30 % ≥ 30 % ≥ 34 % ≥ 36 % ≥ 75 % ≥ 82 % ≥ 90 % ≥ 98 % ≥ 125 % ≥ 150 %

We reserve the right to make technical modifications!

# LoadTracker CHP - DESIGN GUIDE

## APPENDIX (iv) - LoadTracker XRGI 20 data sheet

### TECHNICAL DATA FOR THE XRGI® 20

Product data sheet in accordance with Regulation (EU) No. 811/2013, Dated 26.09.2015



The XRGI® is a combined heat and power plant (CHP) that works on the principle of cogeneration.

An XRGI® system consists of three main components – the Power Unit, Q-Heat Distributor and the iQ-Control Panel. In a package with a Flow Master (temperature control, class II = 2 %) the XRGI® is rated as seasonal space heating energy efficiency class A++.

In addition, you can also extend your XRGI® system with a storage tank with a capacity of 500, 800 or 1,000 litres for optimum operation.

#### ORDERING DATA

Supplier's name or trademark	EC POWER	
	XRGI® 20 without condensing technology <sup>1</sup>	XRGI® 20 with condensing technology <sup>1</sup>
Supplier's model identifier	X200001	X200001+01KIT2616
Article number		
Modules	Power Unit, iQ20-Control Panel, Q80-Heat Distributor	Power Unit, iQ20-Control Panel, Q80-Heat Distributor + Condensing and exhaust gas heat exchanger kit

#### ErP-LABEL DATA<sup>2</sup>

Seasonal space heating energy efficiency class	<b>A++</b>	<b>A++</b>
Rated heat output $P_{rated}$	39 kW	42 kW
Seasonal space heating energy efficiency; $H_s$	<b>213 %</b>	<b>238 %</b>
Sound power level, indoors $L_{WA}$	63 dB	63 dB
Electrical efficiency; in accordance with heating value $H_i$ $\eta_{el\ CHP100+SUP.0}$	33 %	33 %
All special precautions to be taken during assembly, installation or service	Refer to Commissioning and Service Manual	Refer to Commissioning and Service Manual

<sup>1</sup> Return temperatures as per EN 50465 2015 7.6.1: Without condensing technology 47 °C, with condensing technology 30 °C.

<sup>2</sup> The values were rounded in accordance with the requirements governing product data sheets by Regulation (EU) No. 811/2013.

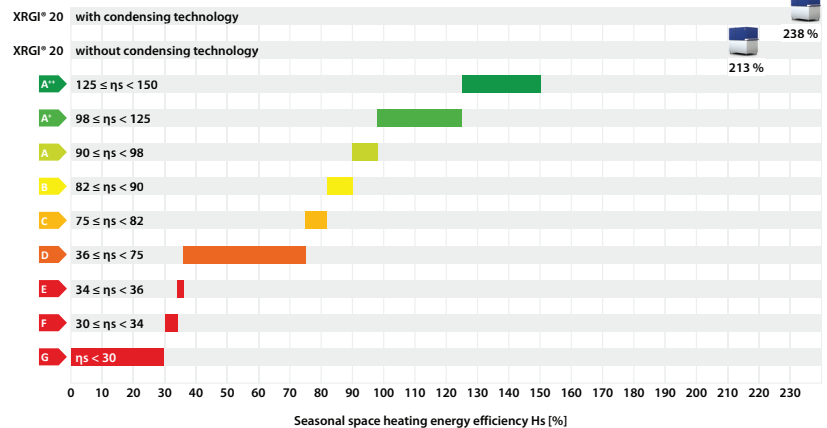
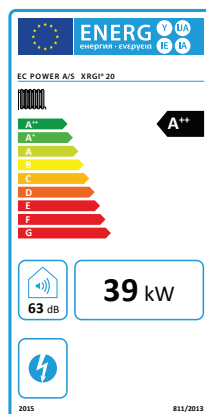



# LoadTracker CHP - DESIGN GUIDE

## APPENDIX (iv) - LoadTracker XRGI 20 data sheet

### OUTPUT

XRGI® system		XRGI® 20 without condensing technology <sup>1</sup>			XRGI® 20 with condensing technology <sup>1</sup>		
Power modulation*		50 %	75 %	100 %	50 %	75 %	100 %
Electrical output, modulating*	kW	10.0	15.0	20.0	10.0	15.0	20.0
Thermal output, modulating*	kW	26.1	31.4	38.7	28.1	34.2	42.2
Power consumption, gas in accordance with Hi	kW	37.1	48.1	61.1	37.0	48.0	60.8
Electrical own demand, production	kW	0.078	0.078	0.078	0.083	0.082	0.081
Electrical own demand, stand-by	kW		0.025			0.025	

### EFFICIENCIES & OPERATING PARAMETERS

Power modulation*		50 %	75 %	100 %	50 %	75 %	100 %
Electrical efficiency in accordance with Hi	%	26.9	31.1	32.7	26.9	31.2	32.9
Thermal efficiency in accordance with Hi	%	70.4	65.4	63.4	76.0	71.2	69.4
Total efficiency in accordance with Hi	%	97.3	96.5	96.1	102.9	102.4	102.3
Seasonal space heating energy efficiency in operating mode <sup>2,3</sup>	$\eta_{son}$ %		217			242	

### POWER MODULATION

#### Continuous modulation of 10 – 20 kW in power-controlled mode

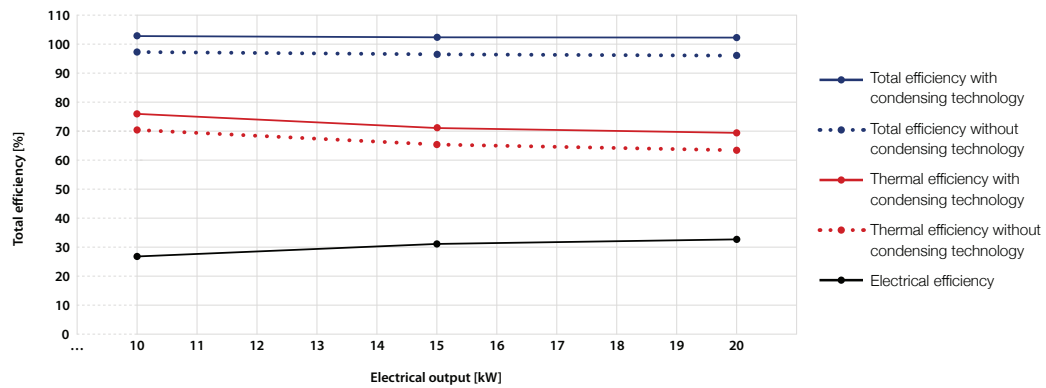

### TOTAL EFFICIENCY AT FULL LOAD

#### XRGI® 20 total efficiency / return temperature

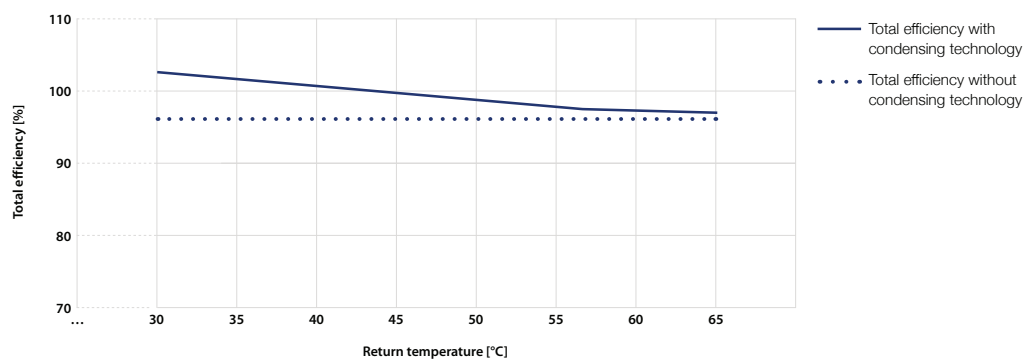

\* Continuous modulation in power-controlled mode

<sup>1</sup> Return temperatures as per EN 50465 2015 7.6.1: Without condensing technology 47 °C, with condensing technology 30 °C.

<sup>2</sup> Based on the values measured by the Danish Gas technology Center and accredited independent third-party organisations.

<sup>3</sup> Efficiency at rated heat output as per the delegated Commission Regulation (EU) No. 811/2013

# LoadTracker CHP - DESIGN GUIDE

## APPENDIX (iv) - LoadTracker XRGI 20 data sheet

### HYDRAULIC INTEGRATION

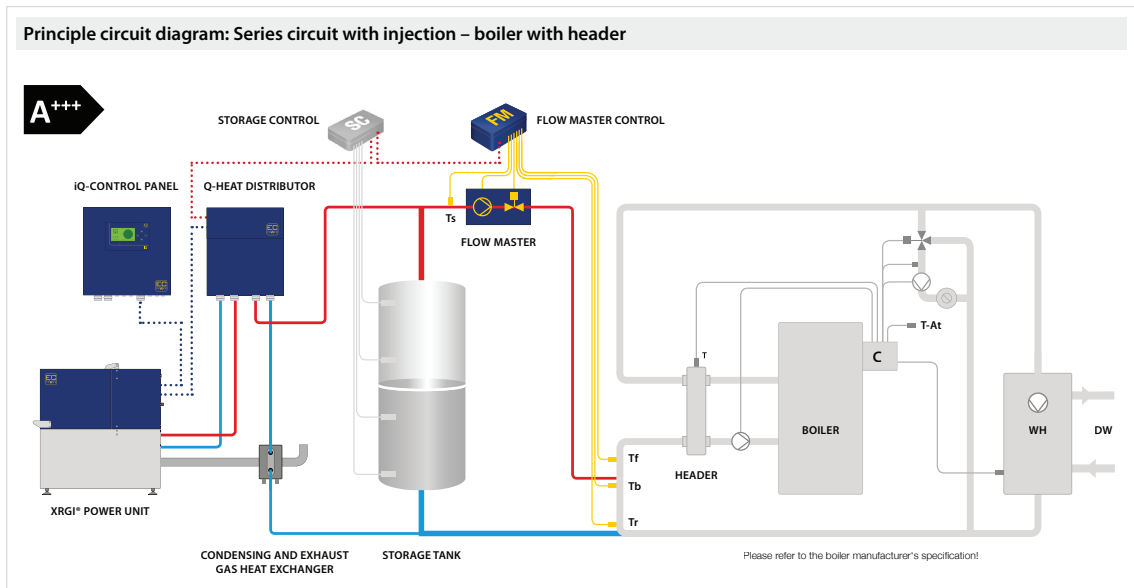

More principle circuit diagrams and information can be found in the EC POWER „Hydraulic Solutions“.

#### NOTE:

If products from other companies are used in the system in addition to EC Power products, EC Power assumes no liability for the accuracy of the energy efficiency class calculation for the entire system.

XRGI <sup>®</sup> system		XRGI <sup>®</sup> 20 without condensing technology <sup>1</sup>	XRGI <sup>®</sup> 20 with condensing technology <sup>1</sup>
Flow temperature, constant	°C	~ 85	~ 85
Return temperature, variable	°C	5-75	5-75

### FUELS

Natural gas (all qualities), propane, butane	yes	yes
--	-----	-----

### EXHAUST GAS

Power modulation		50 %	75 %	100 %	50 %	75 %	100 %	
Max. exhaust gas temperature	°C	-	-	120	-	-	90	
Condensate	kg/h	-	-	-	3.1	3.5	3.7	
Emissions (test data)	CO < 50	mg/Nm <sup>3</sup>	-	-	15	-	-	26
	NOx < 100	mg/Nm <sup>3</sup>	-	-	18	-	-	10

### SOUND

Sound pressure level at a distance of up to 1 m (based on surroundings)	dB(A)	49
---	-------	----

### POWER CONNECTION

Voltage, 3 phases + N + Earth	V	400
Frequency	Hz	50

### SERVICE

Service interval (operating hours)	Hours	6,000
------------------------------------	-------	-------

### DIMENSIONS AND WEIGHT

		XRGI <sup>®</sup> 20 Power Unit	Q80-Heat Distributor	iQ20-Control Panel
Dimensions, W x H x D	mm	750 x 1,170 x 1,250	550 x 600 x 295	600 x 600 x 210
Footprint	m <sup>2</sup>	0.93	wall mounted	wall mounted
Weight	kg	750	44	40

All values are net and have been certified by an independent inspection body. Tolerance ±5 %. Specifications subject to change without notice.

# LoadTracker CHP - DESIGN GUIDE

## APPENDIX (iv) - LoadTracker XRGI 20 data sheet

### TECHNICAL DATA FOR THE XRGI® 20 WITH FLOW MASTER

(Temperature control, Class II = 2 %)

Product data sheet in accordance with Regulation (EU) No. 811/2013, Dated 26.09.2015



Q80 iQ20 FM



Figure shows FM type 350



The Flow Master including Flow Master Control regulates the supply of heat from the XRGI® and from the storage tank to the consumer network. This technology enables a significantly higher heat output to be temporarily made available to the consumer side. This allows peaks of heat demand to be handled by the XRGI®, thereby extending its service life and increasing electricity production.

The 4 models can deliver a heat output of 50, 150, 250 or 350 at a ΔT of 20 K.

#### ORDERING DATA

Supplier's name or trademark	EC POWER			
Supplier's model identifier	XRGI' 20 without condensing technology <sup>1</sup>		XRGI' 20 with condensing technology <sup>1</sup>	
Article number	X200001		X200001+01KIT2616	
Modules	Power Unit, iQ20-Control Panel, Q80-Heat Distributor		Power Unit, iQ20-Control Panel, Q80-Heat Distributor + Condensing and exhaust gas heat exchanger kit	
Supplier's model identifier	Flow Master including Flow Master Control			
FM-type (Temperature control, Class II = 2 %)	FM 50	FM 150	FM 250	FM 350
Article number	17D1130	17D1131	17D1132	17D1133

#### ErP-LABEL DATA<sup>2</sup>

Seasonal space heating energy efficiency class of package	A+++	
Seasonal space heating energy efficiency of package	215 %	240 %
<sup>1</sup> Return temperatures as per EN 50465 2015 7.6.1: Without condensing technology 47 °C, with condensing technology 30 °C.		
<sup>2</sup> The values were rounded in accordance with the requirements governing product data sheets by Regulation (EU) No. 811/2013.		
Seasonal space heating energy efficiency of the space heater with cogeneration	213 %	
Temperature control	Class I = 1 %, Class II = 2 %, Class III = 1,5 %, Class IV = 2 %, Class V = 3 %, Class VI = 4 %, Class VII = 3,5 %, Class VIII = 5 %	
Supplementary boiler	Seasonal space heating energy efficiency in %	
	$( \quad - 'I' ) \times 'II' =$ - $\quad$ %	
Solar contribution (From fiche of solar device)	Tank rating A+ = 0,95, A = 0,91, B = 0,86, C = 0,83, D-G = 0,81	
	$( 'III' \times \quad + 'IV' \times \quad ) \times 0,7 \times ( \quad / 100 ) \times \quad =$ + $\quad$ %	
Seasonal space heating energy efficiency of package	215 %	
Seasonal space heating energy efficiency class of package	G F E D C B A A+ A++ A+++	
	< 30 % ≥ 30 % ≥ 34 % ≥ 36 % ≥ 75 % ≥ 82 % ≥ 90 % ≥ 98 % ≥ 125 % ≥ 150 %	

We reserve the right to make technical modifications!

# ■ LoadTracker CHP - DESIGN GUIDE

## APPENDIX (v) - Heat distributor data sheet

### Q20-/Q80-HEAT DISTRIBUTOR

#### Q20-/Q80-HEAT DISTRIBUTOR



#### STRUCTURE

The Q-Heat Distributor plays an important role in the XRGI® system. It:

- Separates the (primary) engine circuit from the heating network
- Protects the primary circuit
- Controls the engine temperature
- Controls the system temperature
- Manages loading and unloading of the storage tank
- Manages energy flows

Fig. 1. - Q20/Q80



Fig. 2. - Q20

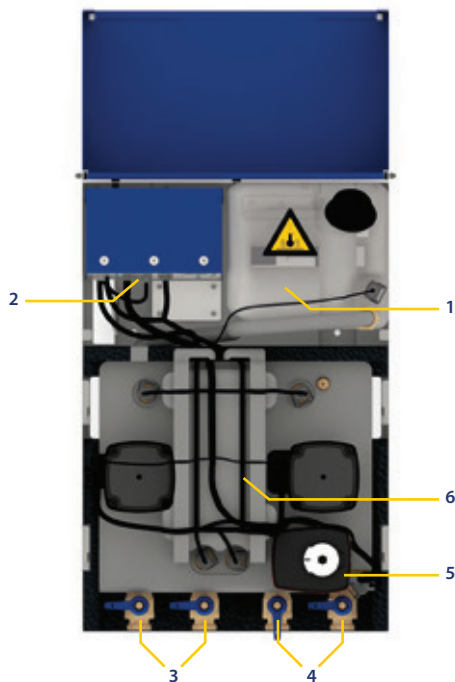
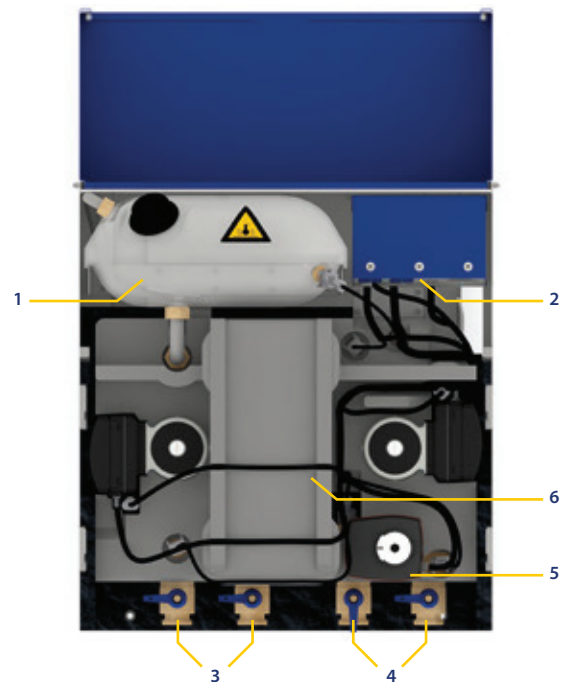

Fig. 3. - Q80



#### Key:

1. Cooling water expansion tank
2. Two connections for Q-Network and two for the iQ-Control Panel and Power Unit.
3. Power Unit connections
4. Storage tank connections
5. Mixer to control the engine temperature
6. Plate heat exchanger

# LoadTracker CHP - DESIGN GUIDE

## APPENDIX (v) - Heat distributor data sheet (continued)

### DIMENSIONS AND CONNECTIONS

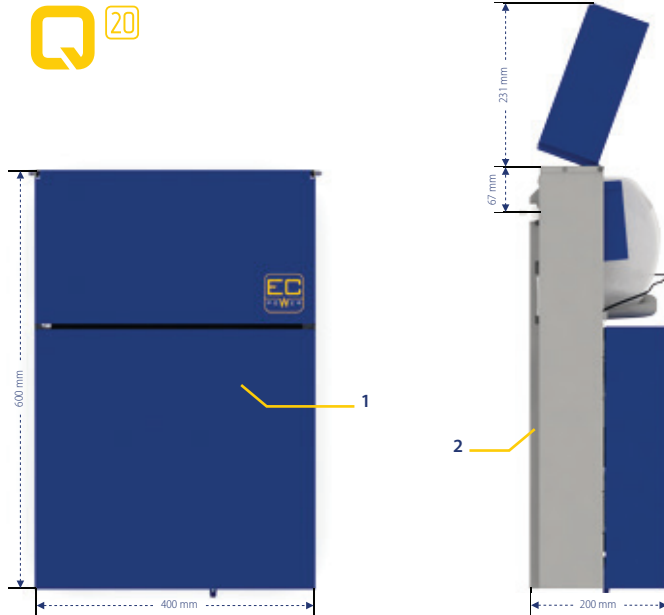

Fig. 4.

Fig. 5.

**Key:**

1. Cover (insulated)
2. Installation plate
3. Power Unit return (1" PT)
4. Power Unit flow (1" PT)
5. Storage tank connection (1" PT)
6. Storage tank connection (1" PT)

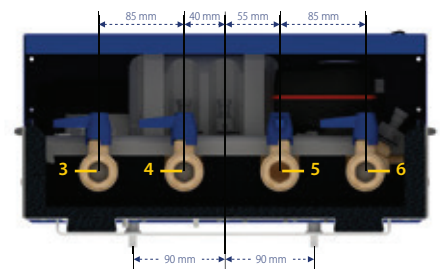

Fig. 6.

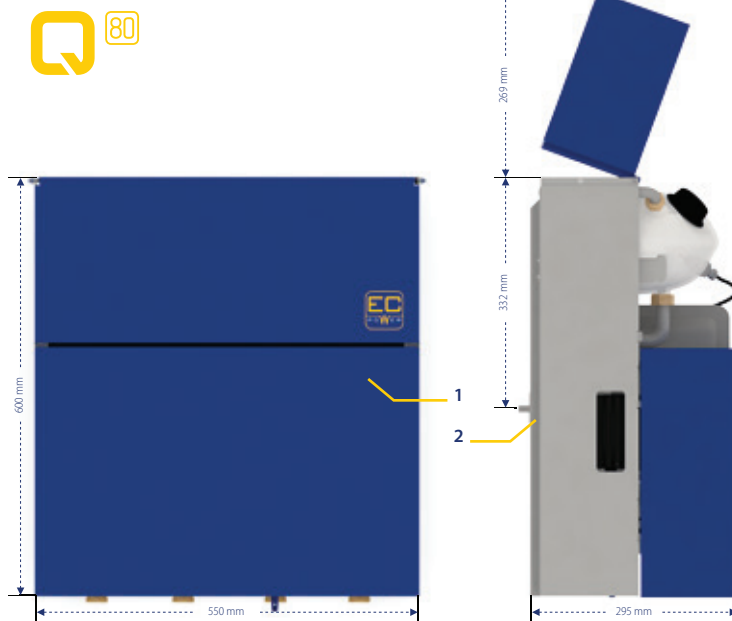

Fig. 7.

Fig. 8.

**Key:**

1. Cover (insulated)
2. Installation plate
3. Power Unit return (1 1/4" PT)
4. Power Unit flow (1 1/4" PT)
5. Storage tank connection (1 1/4" PT)
6. Storage tank connection (1 1/4" PT)

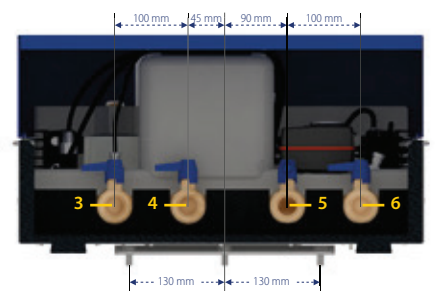

Fig. 9.

# ■ LoadTracker CHP - DESIGN GUIDE

## APPENDIX (v) - Heat distributor data sheet (continued)

### FUNCTION

The Q-Heat Distributor separates the engine circuit (Power Unit cooling water circuit) from the heating system via a plate heat exchanger. The cooling water expansion tank thus protects the engine circuit. The circulation pump for the engine circuit is fitted to the bottom left of the primary Q-Heat Distributor circuit. Once the Q-Heat Distributor is connected to the mains the circulation pumps run for 5 – 10 seconds to check that they are working properly.

The pumps do not need to be configured. They start together with the Power Unit, and stop approx. 10 – 20 minutes after the Power Unit switches off. The power is controlled by the Q-Heat Distributor as required. The storage charging group (bottom right of the Q-Heat Distributor) controls the engine temperature via the assigned mixer and the speed-controlled circulation pump. The system is designed to maximise the storage charging temperatures (80 - 85 °C).

### CONFIGURATION

The Q-Heat Distributor does not need to be adjusted after installation.

### TECHNICAL DATA



#### DIMENSIONS

Dimensions (H x W x D) mm	600 x 400 x 195	600 x 550 x 295
Weight (kg)	25	44

#### CONNECTIONS

Pipe (PT)	1"	1 ¼"
Storage charging circuit	Grundfos: UPM3 15-75 130	Grundfos: UPMXL 25-125 180
Engine water circuit	Grundfos: UPM3 15-75 130	Grundfos: UPMXL 25-125 180
Q-Network connections	Storage Control Flow Master	Storage Control Flow Master
Power consumption at full load (W)		
Stand-by consumption (W)		

#### ENGINE WATER CIRCUIT

Engine heat output (kW)	5 – 20	20 – 80
Permissible cooling water temp. inlet (°C)	95	95
Permissible cooling water temp. outlet (°C, controllable)	80 – 90	80 – 90
Max. permissible pressure in the system (bar)	1,0	1,0
Colling water circulation quantity (m³/h, controllable)	1,0 – 2,1	2,5 – 5,8
Protective valve (bar)	1	1

#### PUMP ENGINE WATER CIRCUIT

Manufacturer	GRUNDFOS	GRUNDFOS
Type	UPM3 15-75 130	UPMXL 25-125 180
Max. transport height (m)	7,5	12,5
Max. transport volume flow: XRG1® 15 (Q80) / XRG1® 9 (Q20) m³/h	2,1	5,8
Pump housing material	Cast iron GS 111B0003	Cast iron EN-GJL-150
Wheel material	Composite	Composite
Type of pipe connection	Rear connection	Rear connection
Nominal pressure (bar)	10	10
Permissible media temperature (°C)	95 (110)	95 (110)
Net weight (dry) (kg)	1,8	2,4
Colour	Aluminium black pump head	Aluminium black pump head
Control signal	PWM	PWM

## ■ LoadTracker CHP - DESIGN GUIDE

### APPENDIX (v) - Heat distributor data sheet (continued)



#### STORAGE CHARGING CIRCUITS

Thermal capacity (kW, adjustable)	5 – 20	20 – 80
Vokume flow (m <sup>3</sup> /h, adjustable)	1,0 – 2,3	2,5 – 6,0
Permissible floe temperature (°C, adjustable)	80 – 90	80 – 90
Max. permissible return temperature (°C)	70	75
Max. permissible pressure in the system (bar)	10	10
Protective valve (bar)	na	na

#### PUMP STORAGE CHARGING CIRCUIT

Manufacturer	GRUNDFOS	GRUNDFOS
Type	UPM3 15-75 130	UPMXL 25-125 180
Max. transport height (m)	7,5	12,5
Max. transport valume flow (m <sup>3</sup> /h)	3	6
Pump housing material	Cast iron GS 111B0003	Cast iron EN-GJL-150
Wheel material	Composite	Composite
Type of pipe connection	Rear connection	Rear connection
Nominal pressure (bar)	10	10
Permissible media temperature	95 (110)	95 (110)
Net weight (dry) (kg)	1,8	2,4
Colour	Aluminium unpainted pump head	Aluminium black pump head
Control signal	PWM	PWM

# LoadTracker CHP - DESIGN GUIDE

## APPENDIX (vi) - Example Assessment

SAV/CHP/SAV /Project/01 Oct 2014  
 Retirement Village  
 LoadTracker CHP (XRGI 20G) -  
 CRA (Carbon Reduction Assessment)

*Please note that the results presented in this assessment are specific to XRGI 20G LoadTracker modulating CHP*

Number of CHP units at 20 kWe 3  
 Recommended heat storage vessel min 500 ltr per CHP  
 Type of usage Retirement Village with 262 apartments

### 1.0 Summary of Usage: [\(SEE APPENDIX\)](#)

Annual electricity consumption 668,527 kWh  
 Electricity price (with CCL) 13.19 p/kWh  
 Annual gas consumption 1,141,258 kWh  
 Gas price (with CCL) 3.48 p/kWh

### 1.1 CO2 Emission Factors used:

- For grid electricity = 0.519 kg/kWh
- For grid displaced electricity = 0.519 kg/kWh
- For gas = 0.216 kg/kWh

### 2.0 Carbon Footprint of Project User Centre:

CO <sub>2</sub> (conv)	593,477 kg CO <sub>2</sub> pa (a)
CO <sub>2</sub> (CHP)	483,921 kg CO <sub>2</sub> pa (b)
Net reduction	109,556 kg CO <sub>2</sub> pa

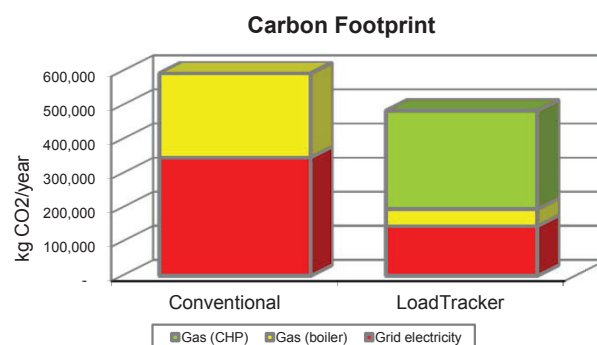

By introducing a CHP, a reduction of 109.6 tonnes of CO<sub>2</sub> emissions (18.5%) could be expected relative to a conventional mains supply/gas boiler system.

Notes:

$$(a) = (\text{electricity consumption} \times 0.519) + (\text{gas consumption} \times 0.216)$$

$$= (668,527 \text{ kWh} \times 0.519) + (1,141,258 \text{ kWh} \times 0.216) = 593,477 \text{ CO}_2 \text{ pa}$$

$$(b) = (\text{CHP gas consumption} \times 0.216) + (\text{supporting boiler gas consumption} \times 0.216) + (\text{electricity consumption} \times 0.519)$$

$$- (\text{CHP electricity production} \times 0.519)$$

$$= (1,334,205 \text{ kWh} \times 0.216) + (231,842 \text{ kWh} \times 0.216) + (668,527 \text{ kWh} \times 0.519) - (387,881 \text{ kWh} \times 0.519) = 483,921 \text{ kg CO}_2 \text{ pa}$$



# LoadTracker CHP - DESIGN GUIDE

## APPENDIX (vi) - Example Assessment (continued)

### 3.0 Cost Savings:

Comparisons are shown between the operational costs of a conventional system (mains supply/gas boiler) and 3 x LoadTracker 20G CHP unit.

	Conv.	CHP
Electricity	£88,179 (c)	£37,017 (d)
Gas (Boiler)	£39,716 (e)	£8,068 (f)
Gas (CHP)	0	£46,430 (g)
<b>Total</b>	<b>£127,894</b>	<b>£91,516</b>

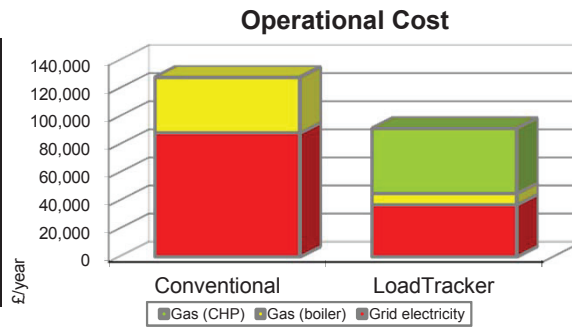

The use of LoadTracker CHP would result in annual savings of £127,894 - £91,516 = £36,379 pa relative to a conventional mains supply/boiler system.

Notes:

(c) = 668,527 kWh x 0.1319 £/kWh = £88,179

(d) = Assessed by LoadTracker programme

(e) = 1,141,258 kWh x 0.0348 £/kWh = £39,716

(f) = Assessed by LoadTracker programme

(g) = Assessed by LoadTracker programme

### 4.0 LoadTracker CHP Contribution to Electrical Needs of User Centre

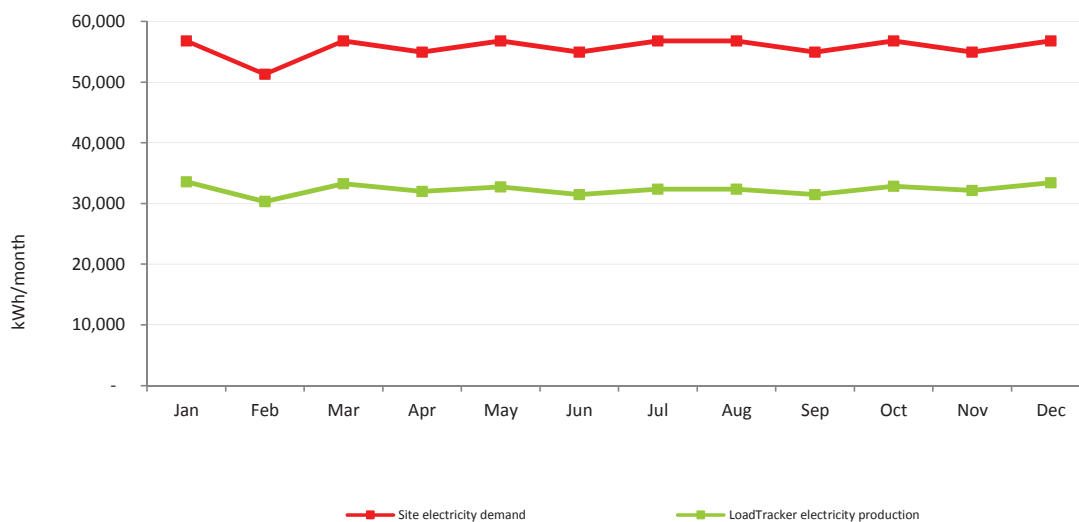

CHP accounts for 387,881 kWh / 668,527 kWh = 58% of electricity requirements of the User Centre.

# LoadTracker CHP - DESIGN GUIDE

## APPENDIX (vi) - Example Assessment (continued)

### 5.0 LoadTracker CHP Contribution to Heat Needs of User Centre

The CHP LoadTracker units can maintain a similar profile for heat production, as shown below:

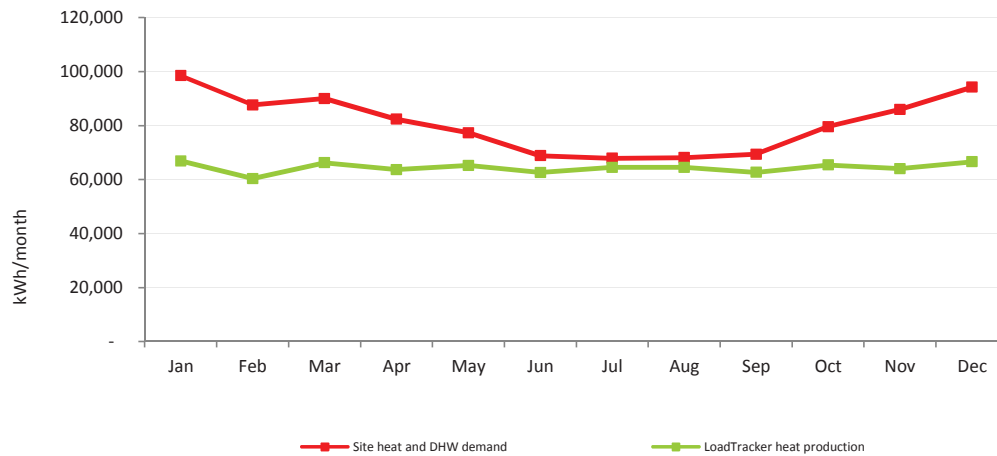

### 6.0 Heat Balance for User Centre

Heat consumption by User Centre	970,069 kWh (h)
Heat production (CHP)	773,004 kWh (i)
Heat production (boiler)	197,066 kWh (j)
Consumption by boiler	231,842 kWh (k)

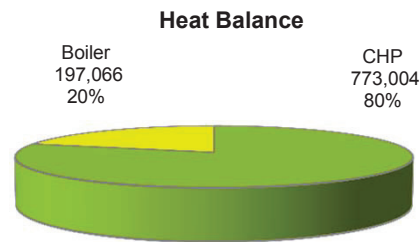

It can be seen that CHP account for  $773,004 \text{ kWh} / 970,069 \text{ kWh} = 80\%$  of heat requirements of the user centre.

Notes:

(h) =  $1,141,258 \text{ kWh} @ 85\%$  (assumed boiler efficiency) = 970,069 kWh

(i) = Assessed by LoadTracker programme, to give max possible CHP usage

(j) = Net difference (h) - (i)

(k) = Heat production (j) factored up assuming 85% efficiency =  $197,066 / 0.85$

## ■ LoadTracker CHP - DESIGN GUIDE

---

### APPENDIX (vi) - Example Assessment (continued)

#### Appendix

CCL = Climate Change Levy. Exemption from this is granted to projects containing good quality CHP.

#### Site Electrical & Gas Consumption

##### Non residential:

##### Heating + DHW

208,680 kWh

##### Gas Consumption (/ .85)

245,506 kWh

##### Electricity

144,527 kWh

##### Residential

##### Heating

332,673 kWh

##### DHW

563,079 kWh

DHW share =  $563,079 / (563,079 + 332,673)$

##### Electricity

Estimated 2,000 kWh per apartment x 262 apartments

524,00 kWh

#### NOTES:

Boiler Efficiency @ 85%

DHW share average @ 78%

## APPENDIX (vii) - Example plant room layout

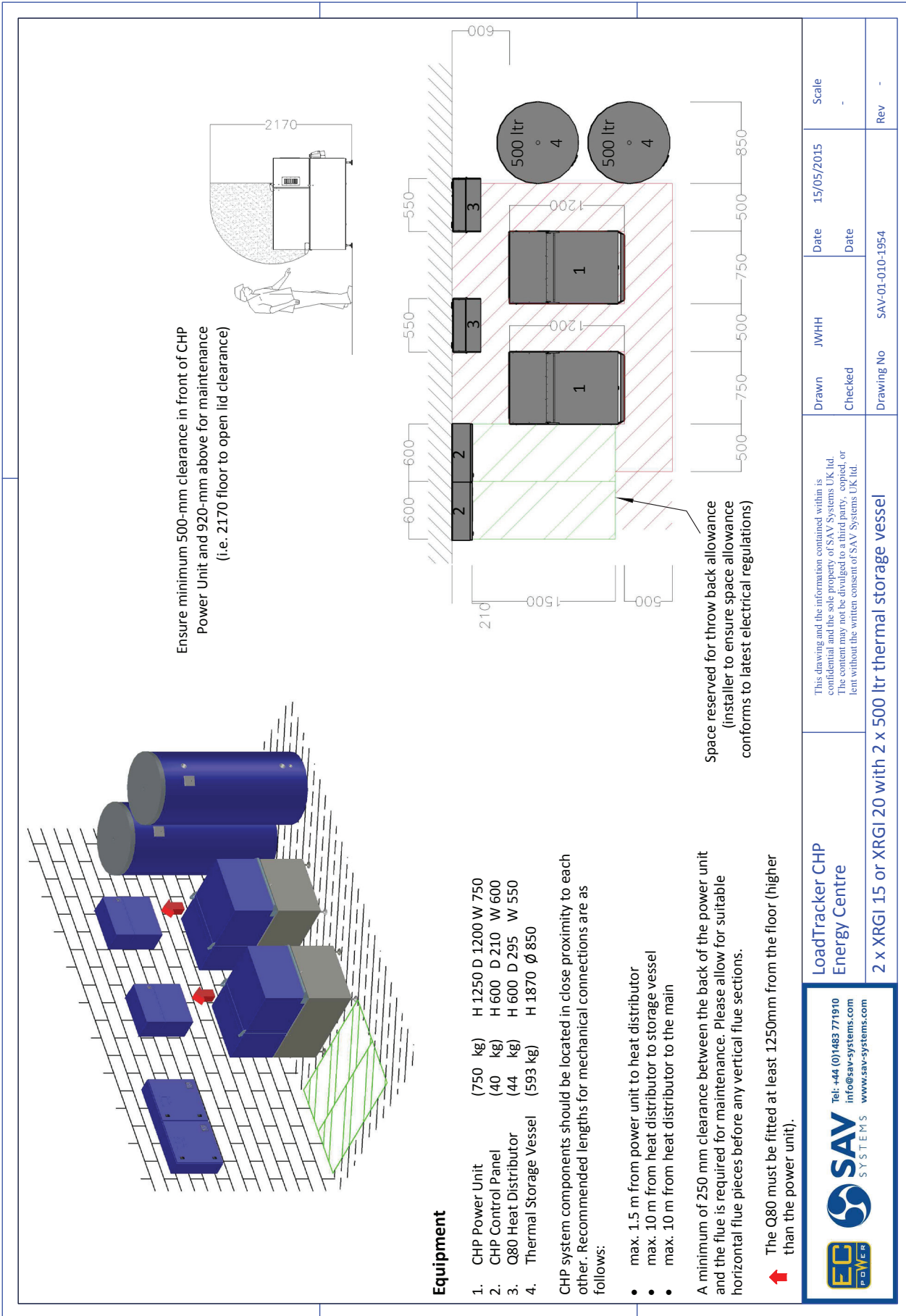

**NOTES**

**NOTES**





## Helping Building Services Engineers Apply Low Carbon Technologies

Origen Energy Ltd.'s, is the exclusive distribution partner of EC Power/SAV Systems.

Origen Energy Ltd.'s, technical team can help specifiers to successfully integrate modules into their projects. Specially prepared design guides are also available.

Origen Energy Ltd.'s, modules are delivered pre-packaged and pre-tested to integrate easily into modern, fast-track construction programs.

- Combined Heat and Power
- Gas Absorption Heat Pumps
- Air & Ground Source Heat Pumps
- Heat Interface Units
- Chillers
- District Heating
- Solar & PV Systems
- Biomass Boilers

### REPUBLIC OF IRELAND CUSTOMER SUPPORT CENTRE

#### Origen Energy Limited

Muirfield Drive, Naas Road, Dublin 12, Ireland  
Unit L, Furry Park Industrial Estate, Santry, Dublin 9  
South Ring West Business Park, Tramore Road, Cork

Tel: +353 1 419 1940  
Tel: +353 1 842 7037  
Tel: +353 21 432 1066

Fax: +353 1 419 1980  
Fax: +353 1 842 7045  
Fax: +353 21 4321068